

Sears

owner's
manual

**MODEL NO.
536.918300**

CAUTION:

Read
INSTRUCTIONS
carefully

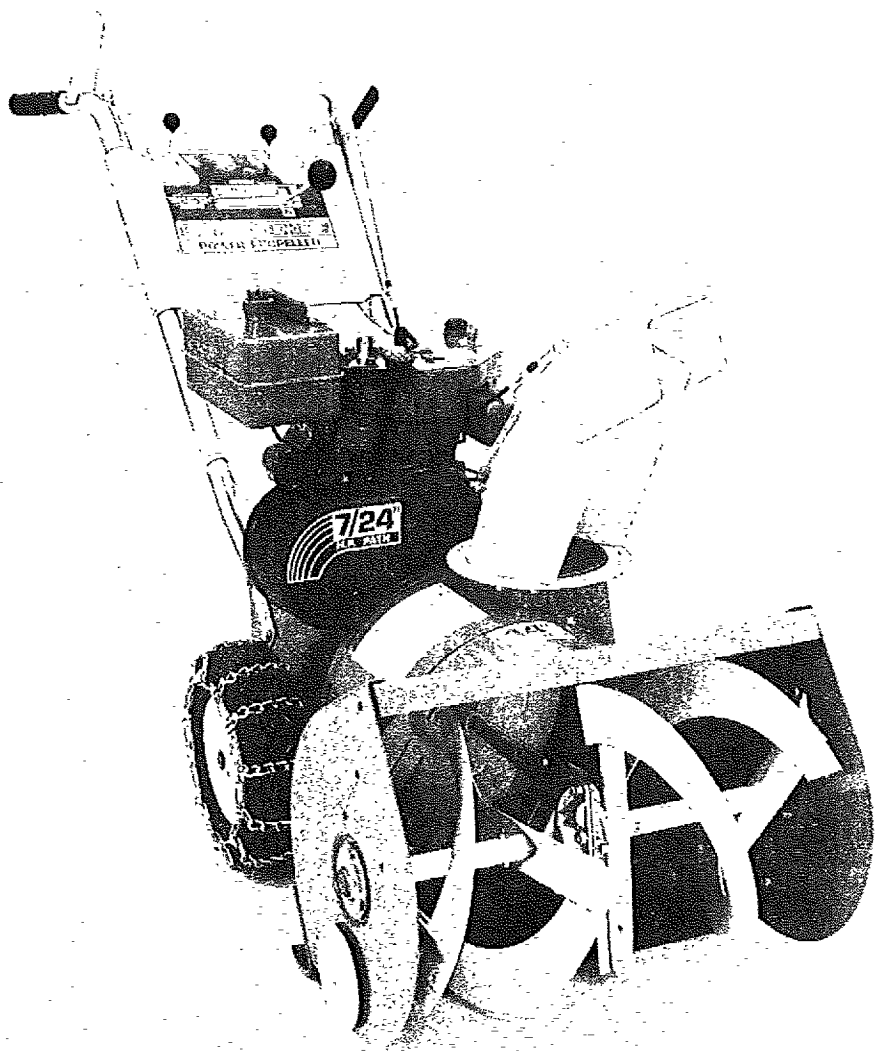

Sears

CRAFTSMAN®

24" SNOW THROWER

- **Assembly**
- **Operating**
- **Maintenance**
- **Repair Parts**

SEARS, ROEBUCK AND CO., Chicago, Illinois 60684 U.S.A.



Look for this symbol. It means — **ATTENTION! BECOME ALERT! A HAZARD TO OPERATOR, BYSTANDERS, PROPERTY OR UNIT MAY EXIST.**



TABLE OF CONTENTS

	Page		Page
OWNERS INFORMATION	2	Impeller/Auger Control Cable Adjustment	10
MAINTENANCE AGREEMENT	2	Carburetor Adjustment	10
WARRANTY	2	Spark Plug Adjustment	10
OPERATIONAL PRECAUTIONS	3	MAINTENANCE	10-12
Contents of Shipping Carton	4	Drive Belt Replacement	10,11
Tools Required for Assembly	4	Shear Bolt Replacement	11
ASSEMBLY	4-6	Roller Chain Replacement	11
Handle Assembly	4	Transmission Replacement	11
Controls Assembly	4,5	Snow Chain Removal	11
Skid and Gage Wheel (Height) Adjustment	6	Lubrication	11,12
OPERATION	6-8	Engine Service	12
Operating Controls	6,7	STORAGE	12
Snow Thrower Operation	7	Engine Storage	12
Before Starting Engine	7,8	Unit Storage	12
To Start Engine	8	LUBRICATION CHART	13
ADJUSTMENTS	8-10	UNIT REPAIR PARTS	14-21
Drive Belt Adjustment	8,9	ENGINE REPAIR PARTS	22-25
Chute Deflector Cable Adjustment	9	TRANSMISSION REPAIR PARTS	26
Power Clutch Cable Adjustment	9	SERVICE HELPS CHART	27
Wheel Drive Control Adjustment	9,10	HOW TO ORDER REPAIR PARTS	28

OWNER'S INFORMATION

Record the following information about your unit so that you will be able to provide it in case of loss or theft.

DATE PURCHASED: _____ MODEL NO.: 536.918300 CODE NO.: _____
 STORE WHERE PURCHASED: ADDRESS _____
 CITY _____ STATE _____ TELEPHONE _____

MAINTENANCE AGREEMENT

The Craftsman Warranty, plus a Maintenance Agreement, provide maximum value for Sears products. Contact your nearest Sears store for details.

CRAFTSMAN WARRANTY

FULL ONE YEAR WARRANTY ON CRAFTSMAN SNOW THROWER

If this Snow Thrower fails to perform properly due to a defect in material or workmanship within one year from the date of purchase, Sears will repair it, free of charge.

WARRANTY SERVICE IS AVAILABLE BY SIMPLY CONTACTING THE NEAREST SEARS STORE OR SERVICE CENTER THROUGHOUT THE UNITED STATES.

This warranty gives you specific legal rights, and you may have other rights which vary from state to state.

SEARS, ROEBUCK AND CO. SEARS TOWER BSC 41-3 CHICAGO, IL 60684

OPERATIONAL PRECAUTIONS



It is imperative in operating and handling your **Snow Thrower** that certain normal precautions be observed to prevent the possibility of injury or damage. Please read the following operational precautions before you assemble or use your new **Snow Thrower**.



TRAINING

1. Wear safety glasses or eye shields when assembling or operating snow thrower.
2. Read the Owner's Manual carefully. Be thoroughly familiar with the controls and the proper use of the equipment. Know how to stop the unit and disengage the controls quickly.
3. Never allow children or young teenagers to operate equipment and instruct them to stay away from the unit while it is operating. Never allow adults to operate equipment without proper instruction.
4. Keep the area of operation clear of all persons, especially small children and pets.
5. Exercise caution to avoid slipping or falling, especially when operating in reverse.

PREPARATION

1. Thoroughly inspect the area where the equipment is to be used and remove all door mats, sleds, boards, wires, and other foreign objects.
2. Disengage all clutches and shift into neutral before starting engine or motor.
3. Do not operate equipment without wearing adequate winter outer garments. Wear footwear which will improve footing on slippery surfaces.
4. Handle gasoline with care - it is highly flammable.
 - A. Use only approved gasoline containers.
 - B. Never remove fuel tank cap or add gasoline to a running or hot engine or fill fuel tank indoors.
 - C. Replace fuel tank cap securely and wipe any spilled gasoline at once.
 - D. Check your fuel supply before each use, allowing space for expansion as the heat of the engine and/or sun can cause gasoline to expand.
5. Use a grounded three wire plug-in for all units with electric starting motors.
6. Adjust auger housing height to clear gravel or crushed rock surfaces.
7. Never attempt to make any adjustments, except where required, while engine is running.
8. Let engine and machine adjust to outdoor temperatures before starting to clear snow.

OPERATION

1. Do not put hands or feet near rotating parts. Keep clear of discharge opening at all times.
2. Exercise extreme caution when operating on or crossing a gravel drive, walks, or roads. Stay alert for hidden hazards or traffic. Do not carry passengers.
3. After striking a foreign object, stop the engine, remove wire from spark plug, thoroughly inspect the snow thrower for any damage, and repair the damage before restarting and operating the snow thrower.
4. If the unit should start to vibrate abnormally, stop the engine and check immediately for the cause. Vibration is generally a warning of trouble.

5. Stop engine whenever you leave the operating position, before unclogging the auger/impeller housing or discharge chute, and making any repairs, adjustments, or inspections.

6. Take all possible precautions when leaving the machine unattended. Disengage the auger/impeller, shift into neutral, stop the engine, and remove the key.

7. When cleaning, repairing, or inspecting, make certain auger/impeller and all moving parts have stopped. Disconnect spark plug wire and keep wire away from plug to prevent accidental starting.

8. Do not run engine indoors, except when starting engine and for transporting snow thrower in or out of building. If for some reason engine must be run indoors, open outside doors. Exhaust fumes contain carbon monoxide which is odorless and deadly poisonous.

9. Do not clear snow across the face of slopes. Exercise extreme caution when changing direction on slopes. Do not attempt to clear steep slopes.

10. Never operate snow thrower without guards, plates or other safety protective devices in place.

11. Never operate snow thrower near glass enclosures, automobiles, window wells, drop-off, etc. without proper adjustment of snow discharge angle.

12. Do not overload machine capacity by attempting to clear snow at too fast a rate.

13. Do not change engine governor settings. The governor controls the speed and protects the engine from excessive, damaging speeds.

14. Never operate machine at high transport speeds on slippery surfaces. Use care when backing.

15. Never direct discharge at bystanders or allow anyone in front of unit.

16. Disengage power to auger/impeller when transporting unit or when unit is not in use.

17. Use only accessories approved by manufacturer of the snow thrower (such as tire chains, electric start kits, etc).

18. Never operate the snow thrower without good visibility or light. Always be sure of your footing and keep a firm hold on the handles and walk, never run.

MAINTENANCE AND STORAGE

1. Check shear bolts, engine mounting bolts, etc., at frequent intervals for proper tightness to be sure equipment is in safe working condition.

2. Run machine a few minutes after throwing snow to prevent freeze up of auger/impeller.

3. Never store gasoline or equipment with gasoline in the tank inside of a building where fumes may reach an open flame or spark. Never store your snow thrower for prolonged periods (more than 15 days) with gasoline in the fuel tank. Store gasoline and your snow thrower in a locked safe storage area secure from children and others.

CONTENTS OF SHIPPING CARTON

- 1 - 24 inch Snow Thrower (completely assembled except for handles, controls and headlight).
- 1 - Can of Engine Oil
- 1 - Upper Chute Control Rod
- 1 - Left Hand Handle Assembly
- 1 - Right Hand Handle Assembly (with clutch lever attached)
- 1 - Control Panel Assembly
- 1 - Bag of Assembly Parts Containing:
 - 1 - 3/4 inch Flatwasher
 - 2 - 5/16 inch Split Lockwasher
- 10 - Formed (curved) Washers
- 4 - No. 10 x 1/2 inch Hex Head Screws
- 4 - No. 10 Locknuts
- 2 - 5/16 x 5/8 inch Hex Head Screws
- 2 - 5/16 x 1 inch Hex Head Screws
- 8 - 5/16 x 1 3/4 inch Hex Head Screws
- 8 - 5/16 inch Locknuts
- 1 - 3/8 x 3/4 inch Hex Head Screws
- 1 - 3/8 inch Locknut
- 1 - Cable Clamp (metal)
- 2 - Knobs (for Throttle and Impeller/Auger Drive Levers)
- 1 - Bag of Shear Bolt Replacement Parts (Not used in assembly) Containing:
 - 3 - 5/16 x 1 3/4 inch Shear Bolts
 - 3 - 5/16 inch Locknuts
 - 1 - Instruction Sheet

TOOLS REQUIRED FOR ASSEMBLY

- 1 - 3/8 inch Wrench (or adjustable wrench)
- 1 - 5/16 inch Wrench (or adjustable wrench)
- 2 - 1/2 inch Wrenches (or adjustable wrenches)
- 2 - 7/16 inch Wrenches (or adjustable wrenches)
- 2 - 9/16 inch Wrenches (or adjustable wrenches)
- 1 - Hammer (plastic or rawhide head recommended)

ASSEMBLY

Your Snow Thrower is right or left hand as you face the unit from operator position.

Figure 1 shows the Snow Thrower completely assembled. To complete the assembly, proceed as follows:

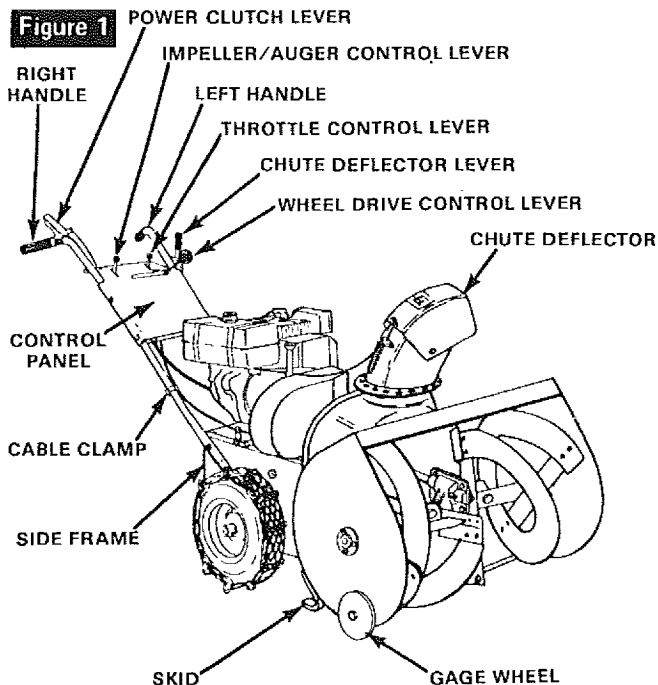

⚠ DANGER ⚠

The operation of any powered equipment can result in foreign objects being thrown into the eyes, which can result in severe eye damage. Always wear safety glasses or eye shields while assembling or operating Snow Thrower.

HANDLE ASSEMBLY

Right handle has a lever (power clutch) attached to upper end. Nuts used to attach lower end of handles are attached to inside of side frame.

1. Attach right lower handle to side of side frame as shown in figure 2. Handle grip should be tilted down and out when handle is properly installed.
2. Repeat step 1 for left handle.

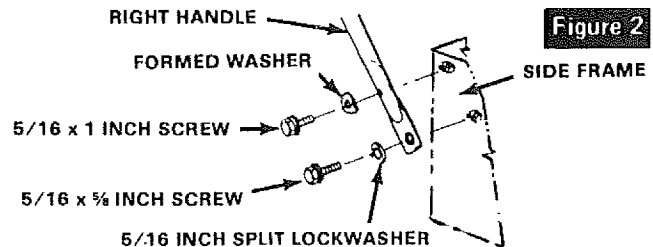

CONTROLS ASSEMBLY

1. Attach control panel to handles as shown in figure 3. **NOTE:** Attach panel with lower screw only on left side.

2. Attach chute deflector lever as shown in figure 3. **NOTE:** Place a 5/16 inch flatwasher between lever assembly and handle at top screw position.

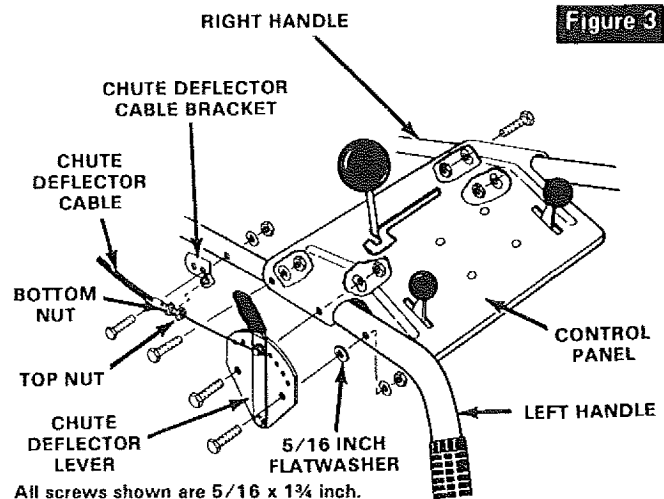

All screws shown are 5/16 x 1 3/4 inch.

All locknuts shown are 5/16 inch.

A formed washer is used on inside of handle at all screw locations.

3. To attach chute deflector cable bracket (attached to cable), proceed as follows:

- A. Place chute deflector lever in lowest (forward) notch.
- B. Grasp chute deflector cable bracket and pull down until a 5/16 x 1 3/4 inch screw can be placed through bracket and through left handle as shown in figure 3. **NOTE:** Only one of holes in cable bracket is large enough for mounting screw.

4. Cable length will need to be adjusted if chute deflector lever will not move all the way up to top notch in bracket or if

cable is loose and sags when lever is pushed all the way down to last notch. **To adjust cable:**

- A. Loosen bottom nut on power clutch cable (figure 4) and tighten top nut until lever will reach top notch.
- B. Loosen top nut and tighten bottom nut to remove looseness from cable when lever is in bottom notch.

5. Attach throttle control lever assembly (other end of cable attached to left rear of engine) to control panel as shown in figure 4 by:

- A. Insert lever up through slot in left side of control panel.
- B. Attach with two No. 10 x 1/2 inch hex washer head screws and two No. 10 locknuts. **NOTE:** Before tightening screws and locknuts, check to make sure that lever does not rub side of slot in control panel.

6. Attach impeller/auger drive control lever (other end of cable is attached on right side of unit below gas tank) to control panel as shown in figure 4 by:

- A. Insert lever up through slot in right side of control panel.
- B. Attach with two No. 10 x 1/2 inch hex washer head screws and two No. 10 locknuts. **NOTE:** Before tightening screws and locknuts, check to make sure that lever does not rub side of slot in control panel.
- C. Attach impeller/auger drive control cable to handle with a cable clamp.
- D. Place a knob onto throttle and impeller/auger drive control levers and tap firmly with a hammer until knobs will not pull off. **CAUTION:** Knobs are made of plastic and will break if hit too hard. A plastic or rawhide hammer is recommended.

7. A power clutch cable is attached under belt cover in front of engine. Cable should wrap around left side of engine and under carburetor. Attach cable by:

- A. Remove top nut from threaded end of cable and slide cable through slot in lower edge of control panel.

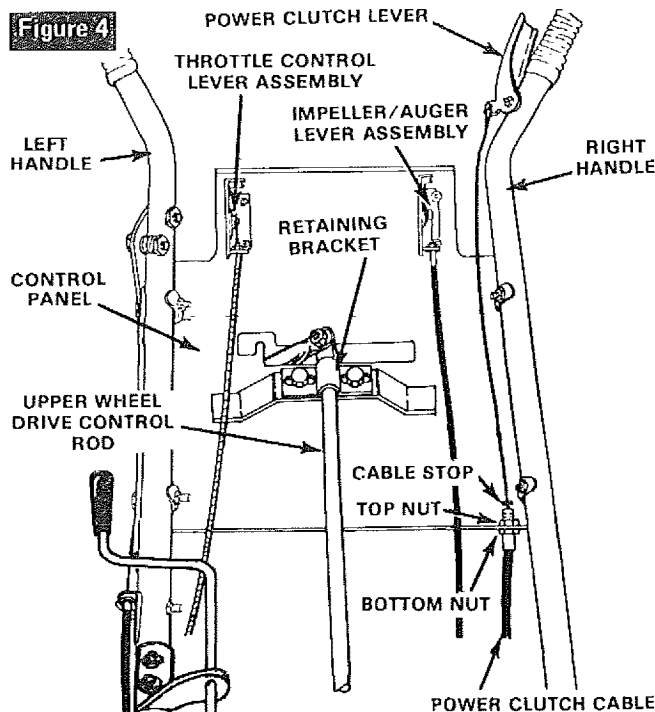

B. Push threaded end of cable up through hole in control panel and replace, but do not tighten, top nut.

C. Hook loop end of power clutch cable over pin on power clutch lever (figure 4). **NOTE:** It may be necessary to loosen bottom nut on cable to lengthen cable enough to hook over pin on clutch handle.

D. Tighten bottom nut on power clutch cable until cable stop (figure 4) just clears top end of threaded portion of cable. Tighten top nut to complete assembly.

8. Attach upper chute control rod and upper chute control rod bracket (mounted on rod) to bottom side of left handle (figure 5) with two 5/16 x 1 3/4 inch hex head screws, two 5/16 inch locknuts, and two formed washers.

9. Remove the 1 inch screw and locknut from pivot block (part of universal bracket) located on end of lower rod (figure 5). Insert lower end of upper rod onto pivot block in universal bracket (figure 5) on lower chute control rod and secure with the removed screw and locknut. **CAUTION:** Do not tighten locknut against universal bracket. This screw and nut must be loose enough to allow universal to move freely.

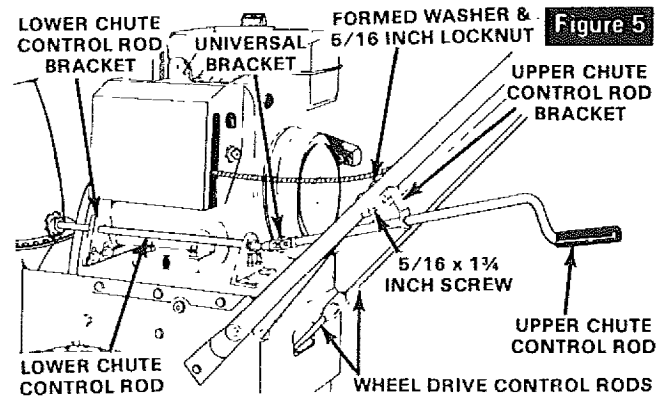

10. Check sprocket end of chute control rod to make sure teeth on sprocket fully engages holes in flange around bottom of discharge chute. If adjustment is necessary, simply loosen screws attaching lower chute control rod bracket to main frame and slide bracket up or down until teeth on sprocket fully engages holes in flange.

11. Attach upper wheel drive control rod to lower wheel drive control rod as follows:

- A. Place wheel drive control lever in NEUTRAL position.
- B. Attach upper and lower rod ends with a 3/8 x 3/4 inch screw and 3/8 inch locknut as shown in figure 6 and tighten securely. **NOTE:** If rod ends do not line up, proceed with the following steps.
- C. Loosen screws in retaining bracket at top end of upper wheel drive rod (below control panel).
- D. Move rod left or right (make sure lever stops in NEUTRAL position) until holes in rods line up and place 3/8 x 3/4 inch screws through both rods. Tighten securely.
- E. Retighten loosened screws on retaining bracket.

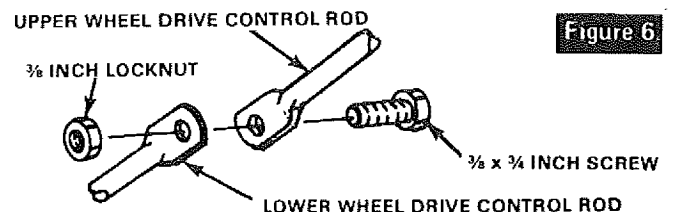

SKID and GAGE WHEEL (Height) ADJUSTMENT

⚠ CAUTION ⚠

For packing purposes, the gage wheels on this unit were adjusted all the way up to lowest height position. Adjust height as instructed below before using snow thrower.

This unit is equipped with a pair of skids mounted on the back side of the auger housing and a pair of gage wheels located on the outside of the auger housing. Both the skids and gage wheels are used to elevate the front of the machine up to 1 inch. Figure 7 shows both parts.

When removing snow from hard surface area such as paved driveway or sidewalk, we suggest use of gage wheels only, to elevate front of machine to desired height. **To change height of gage wheels:**

1. Remove locknut on shoulder bolt through gage wheel (figure 7).
2. Relocate shoulder bolt into hole representing desired height and replace locknut.
3. Set wheel on other side at same height.
4. Loosen, pull up and tighten skids to full UP position after gage wheels have been set.

Figure 7

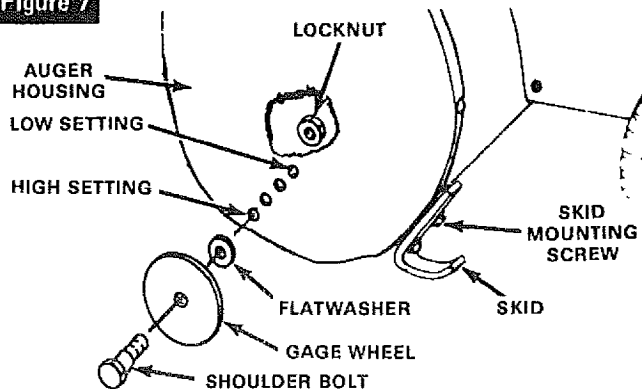

When removing snow from rock or unpaved construction; we suggest you raise the front of the machine with the skids. **To raise the machine with the skids:**

1. Loosen the skid mounting nuts (figure 7) and push the skid down until the front of the machine is raised to desired height. Retighten mounting nuts.
2. Set skid on other side at same height. **NOTE:** Be sure that front of unit is set at same height on both sides.

⚠ DANGER ⚠

Be certain to maintain proper ground clearance for your particular area to be cleared. Objects such as gravel, rocks or other debris, if struck by the impeller/auger, may be thrown with sufficient force to cause personal injury or property damage.

OPERATION

The operation of any powered outdoor equipment can result in foreign objects being thrown into the eyes, which can result in severe eye damage. Always wear safety glasses or eye shields before beginning snow thrower operation. We recommend Wide Vision Safety Mask for over spectacles or standard safety glasses, available at SEARS Retail or Catalog Stores.



Familiarize yourself with the equipment and with the **Operational Precautions.**

OPERATING CONTROLS

Operating controls (figures 8 & 9) and their functions are as follows:

- **Power Clutch Lever** - The power clutch lever controls forward or reverse motion of the unit when the wheel drive control lever is in the appropriate position. When the operator's hand is removed from the power clutch lever, tension is removed from drive belts, therefore unit motion and impeller/auger rotation stop. Engage slowly but firmly and all the way down against hand grip.
- **Impeller/Auger Drive Control Lever** - Used to disengage power to impeller/auger without interfering with power to drive wheels. Pull up to engage. Push down to disengage. **NOTE:** Power clutch lever must be in released (disengaged) position before impeller/auger lever position is changed.
- **Throttle Control Lever** - This snow thrower is equipped with a control panel mounted throttle control lever used to control speed of engine. There are three positions on the throttle control - Stop - Slow - Fast.
- **Wheel Drive Control Lever** - Used to select desired unit speed or direction. Choice of five forward speeds, neutral and reverse.
- **Chute Deflector Lever** - The distance snow will be discharged can be adjusted by raising chute deflector (figure 8) for more distance, or lowering for less distance. Pull lever up to top notch for most distance. Push lever down to bottom notch for least distance.

⚠ DANGER ⚠

Do not put hands in or near the deflector chute while the engine is running.

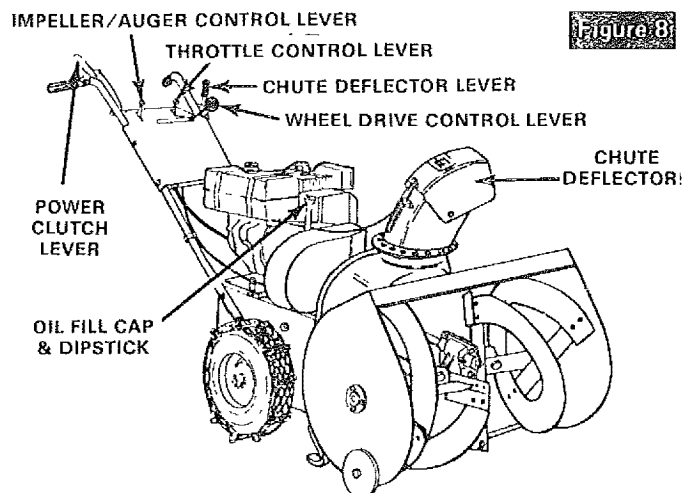

- **Chute Control Rod** - Used to change direction of snow discharge. Turn handle counterclockwise to turn chute to left. Turn handle clockwise to turn chute to right. All snow can be discharged to one side by changing chute direction when changing direction of travel.
- **Choke Lever** - Set choke lever to FULL CHOKE position to start engine.
- **Primer Button** - Used to inject fuel directly into carburetor manifold to insure fast starts.
- **Ignition Switch** - Switch must be turned to ON position to start engine and turned to OFF position to stop engine.
- **Starter Handle** - This unit is equipped with a recoil starter.

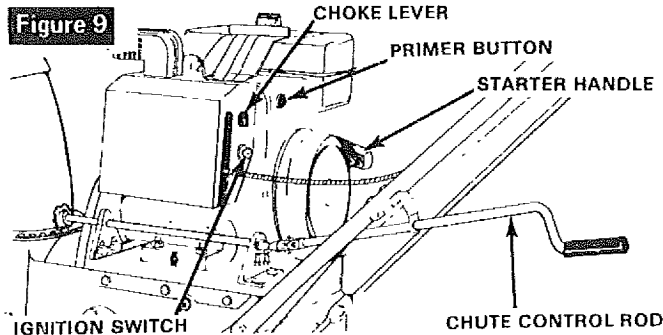

SNOW THROWER OPERATION

The most effective use of the snow thrower will be established by experience, taking into consideration the terrain, wind conditions and the depth and weight of the snow. It is the wind conditions and building location which will determine the direction of the discharge chute. Since the wind will tend to blow the discharged snow back into the cleared area, it will be necessary to change the chute direction to offset this condition. **NOTE:** Do not throw snow towards a building as hidden objects could be thrown with sufficient force to cause damage.

To engage the self-propelling drive mechanism, proceed as follows:

1. Start the engine as described in paragraph To Start Engine.
2. Using the chute control rod (figure 9), position the discharge chute so as to discharge the snow with the wind.
3. Select proper speed for snow conditions as outlined below and set wheel drive control lever to desired position.
 - A. Number 1 position is for extra deep, wet, heavy snow.
 - B. Number 2 position is for deep, wet, heavy snow. Experience will help make choice between position 1 and 2.
 - C. Number 3 position is for light fluffy snow.
 - D. Number 4 position is mainly for transporting unit over bare or plowed areas, but may be used for very light snow.
 - E. Number 5 position is for transporting unit over bare or plowed areas.

⚠ DANGER ⚠

The moment the wheel drive control lever is set in a position other than NEUTRAL and the power clutch lever on the right hand grip is pressed, the snow thrower will move forward.

4. Set the impeller/auger control lever to the ON position.
5. Press the power clutch lever to begin impeller/auger rotation and forward motion. As the unit starts to move, maintain a firm hold on the handles and guide the snow thrower along the cutting path. Do not attempt to push the unit.
6. To disengage the drive mechanism: Release the power clutch lever. Set the wheel drive control lever to the NEUTRAL position. Set the impeller/auger drive control lever to the OFF position.

⚠ DANGER ⚠

Do not attempt to remove any item that may become lodged in auger without taking the following precautions:

1. Move impeller/auger drive control lever to OFF position.
2. Move wheel drive control lever to NEUTRAL position.
3. Move throttle lever to STOP position.
4. Turn key to OFF position.
5. Remove spark plug.
6. Do not place your hands in the auger or discharge chute. Use a pry bar. The engine compression could cause the auger to rotate sharply when lodged item is removed, if above precautions are not followed.

7. To move unit backwards: Place wheel drive control lever in REVERSE position and press the power clutch lever. To stop backward motion: Release pressure from power clutch lever. Return wheel drive control lever to NEUTRAL position.

BEFORE STARTING ENGINE

A can of high quality 5W-20 motor oil is supplied with your unit.

1. Remove the oil cap and dipstick (figure 10) and fill crankcase to the FULL line on dipstick (approximately 1½ pints).
2. Replace the oil cap and dipstick and tighten securely.
3. Always check oil level before starting the engine and after each five hours of continuous use. Add oil as required. Do not overfill.

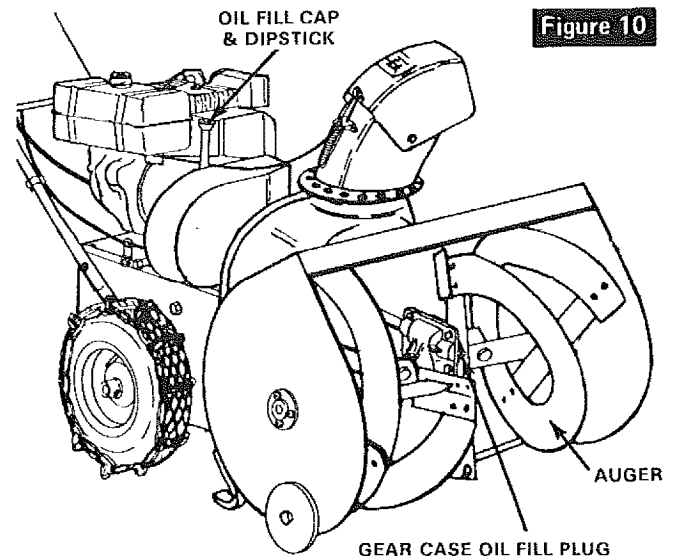

4. Change crankcase oil after the first 2 hours of operation and after each 25 hours of operation thereafter, or at the beginning of each season, whichever comes first.

5. To drain the oil, see paragraph Lubrication in Maintenance section of this manual.

6. Fill gas tank with clean, fresh, unleaded grade automotive gasoline. Leaded regular grade gasoline is an acceptable substitute. **Do not use Ethyl or high octane gasoline.** Be certain container is clean and free from rust or foreign particles. Never use gasoline that may be stale from long periods of storage in the container.

⚠ DANGER ⚠

Never fill the gas tank while engine is running or is hot. Immediately wipe off any spilled gasoline before attempting to start engine.

7. Check oil level in gear case by removing oil level fill plug (figure 10). Oil should be visible in hole. If not, insert a funnel that has an adjustable neck and add SEARS SAE-30 (or equivalent) engine oil until it starts to run out of hole. Replace plug and tighten securely.

TO START ENGINE

The snow thrower engine is equipped with a recoil starter. The operation of this engine is controlled by the throttle control lever (figure 8). Before starting the engine, be certain that you have read and followed all the instructions on the preceding pages.

⚠ DANGER ⚠

Never run engine indoors or in enclosed, poorly ventilated areas. Engine exhaust contains carbon monoxide, an odorless and deadly gas.

Keep hands, feet, hair and loose clothing away from any moving parts on engine and snow thrower.

WARNING - Temperature of muffler and nearby areas may exceed 150° F. Avoid these areas.

1. Move wheel drive control lever (figure 8) to NEUTRAL position.

2. Move impeller/auger control lever (figure 8) to OFF position.

3. Rotate ignition switch key (figure 9) clockwise to ON position.

4. Move throttle control lever (figure 9) to FAST position.

5. Move choke lever (figure 9) to FULL CHOKE position. **NOTE:** Do not choke a warm engine.

6. Push primer button (figure 9) 2 times. **NOTE:** Do not prime a warm engine.

7. Pull starter handle (figure 9) rapidly. **NOTE:** Do not allow starter handle to snap back but rewind slowly while keeping a firm hold of starter handle.

⚠ DANGER ⚠

Do not put hands, feet or loose clothing in or near the deflector chute or auger housing while engine is running.

8. As engine warms up and begins to operate evenly, move choke lever slowly to OFF position. If engine falters, return to ½ choke until it runs smoothly, then move to OFF

choke position. **NOTE:** Allow the engine to warm up for a few minutes as the engine will not develop full power until it reaches operating temperature.

9. Run engine at or near top speed. **NOTE:** To help prevent possible freeze-up of rewind starter, proceed as follows after each snow blowing job:

A. **With engine running**, pull starter rope hard with a continuous full arm stroke three or four times. Pulling of starter rope will produce a loud clattering sound. This is not harmful to the engine or starter.

10. To stop forward motion, release power clutch lever (figure 8) on right handle. To stop engine, move throttle control lever to STOP position and move ignition switch key to OFF position. **NOTE:** To help prevent possible freeze-up of engine controls, proceed as follows after each snow blowing job:

A. **With engine not running**, wipe all snow and moisture from carburetor cover in area of control levers. Also move control levers backward and forward several times.

IMPORTANT: After each use of the snow thrower, stop the engine, remove the ignition key, remove all accumulated snow from the unit and wipe clean. Store the snow thrower in a protected area.

NOTE: To prevent or cure icing of cables and control, a de-icer can be used. De-icer is available in the automotive department of your nearest SEARS Store.

⚠ CAUTION ⚠

Pay close attention to instruction on the de-icer container. Also be extra careful that no de-icer comes in contact with muffler or any other hot area on or near engine.

ADJUSTMENTS

⚠ CAUTION ⚠

Always remove the spark plug before making any repairs or adjustments.

DRIVE BELT ADJUSTMENT

This unit is equipped with two drive belts located just in front of engine under belt cover (figure 11). Figure 12 shows both belts and idler pulleys. Belt nearest engine is unit drive (wheels) belt. Other belt (farthest from engine) is impeller/auger drive belt.

If adjustment becomes necessary due to wear or stretch of either belt:

1. Remove belt cover (figure 11).

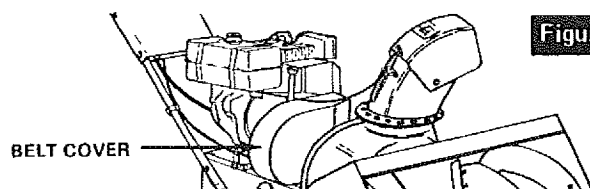

2. Loosen locknut on idler pulley (figure 12) and push idler pulley toward belt until sufficient tension is achieved. Tighten securely.

3. Check belt guides (figure 12) for proper clearances as follows: **IMPORTANT: Never loosen both belt guides at same time. Adjust one belt guide, retighten, then adjust other guide.**

- A. Place impeller/auger lever in ENGAGE position.
- B. Have someone hold power clutch lever down to engaged position.
- C. Adjust left belt guide, if necessary, to a clearance between guide and belt of not more than 1/16 inch.
- D. Adjust right belt guide, if necessary, to a clearance between guide and belt of not less than 1/8 inch or more than 1/4 inch.
- E. Be sure to tighten belt guide mounting screws securely to prevent guides from slipping from adjusted positions.

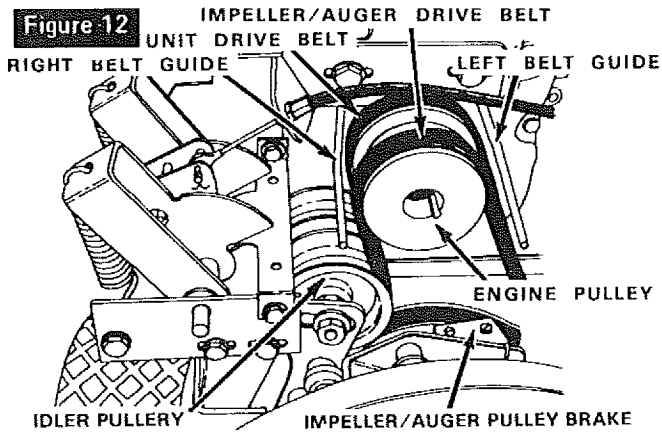

4. A third belt guide is located under belt cover extension (figure 13). To adjust this belt guide, proceed as follows:

- A. Remove two screws that hold belt cover extension in place and remove extension.
- B. Place impeller/auger lever in ENGAGE position.
- C. Have someone hold power clutch lever down to engaged position.
- D. Loosen nut holding belt guide (figure 13) and adjust guide to a clearance from belt of not more than 1/16 inch.
- E. Tighten nut and replace belt cover extension and belt cover.

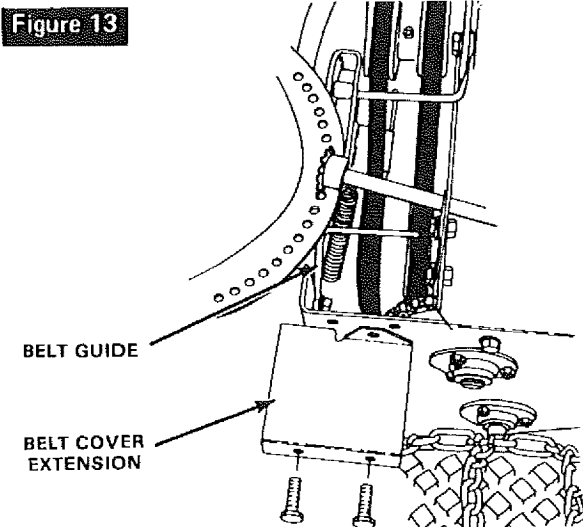

5. A brake (figure 12) that stops impeller/auger pulley when power clutch lever is released is not adjustable. When brake is operating properly, the impeller/auger should stop within 5 seconds after power clutch lever is released. If brake is not operating properly, replace pad as follows:

- A. Use original equipment part. See **Unit Repair Parts** section of this manual for proper part.
- B. Remove two screws from top of brake arm. Replace worn pad with new pad and attach with removed screws.

CHUTE DEFLECTOR CABLE ADJUSTMENT

If adjustment becomes necessary, adjust as instructed in **Step 4** of paragraph **Controls Assembly** in **Assembly** section of this manual.

POWER CLUTCH CABLE ADJUSTMENT

If adjustment becomes necessary, adjust cable length as instructed in **Step 7** in paragraph **Controls Assembly** in **Assembly** section of this manual. If further adjustment is required, proceed as follows:

1. Remove belt cover (figure 11).
2. Loosen screws that hold belt guides and power clutch bracket (figure 14).
3. Move power clutch bracket until pin in selector assembly (figure 14) is centered in holes in impeller/auger and wheel drive arms.
4. Retighten screws.
5. Readjust belt guides as instructed in **Steps 3 and 4** in paragraph **Drive Belt Adjustment**. **NOTE:** Loosen and adjust one belt guide at a time or power clutch bracket may move causing adjustment to be lost.

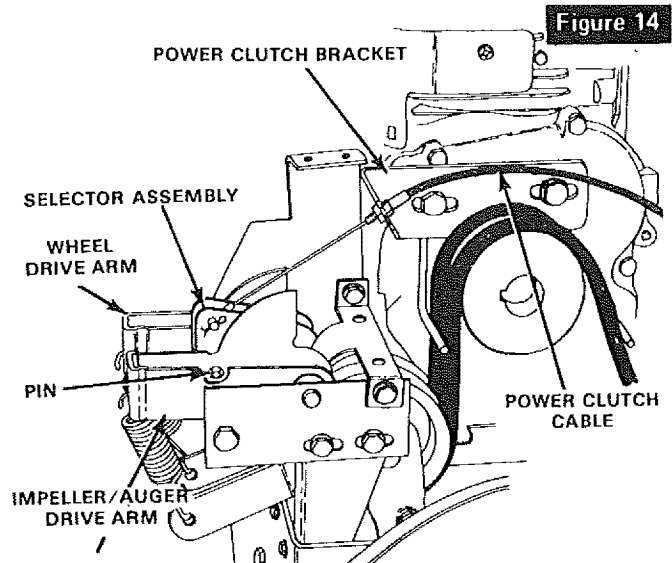

WHEEL DRIVE CONTROL ADJUSTMENT

Adjustment to wheel drive control rod will be necessary if:

1. Unit is not in neutral when wheel drive control lever is in NEUTRAL position.
2. Reverse position can not be fully reached.
3. Fifth (5th) gear can not be fully reached. If any of these three conditions exist, adjust as follows:
 - A. With engine running and power clutch lever depressed, locate neutral position of wheel drive control lever.

- B. Leave wheel drive control lever in position where neutral was obtained and release power clutch lever. Shut off engine.
- C. Loosen screws in retaining bracket (figure 15) at top end of wheel drive control rod (under control panel).
- D. Slide retaining bracket and rod left or right until wheel drive control lever is in proper neutral position. Tighten screws in retaining bracket.
- E. Start engine and check adjustment by moving lever to each position. **NOTE:** Be sure to check to see that NEUTRAL is properly reached from both directions (from reverse and from forward gear).

Figure 15

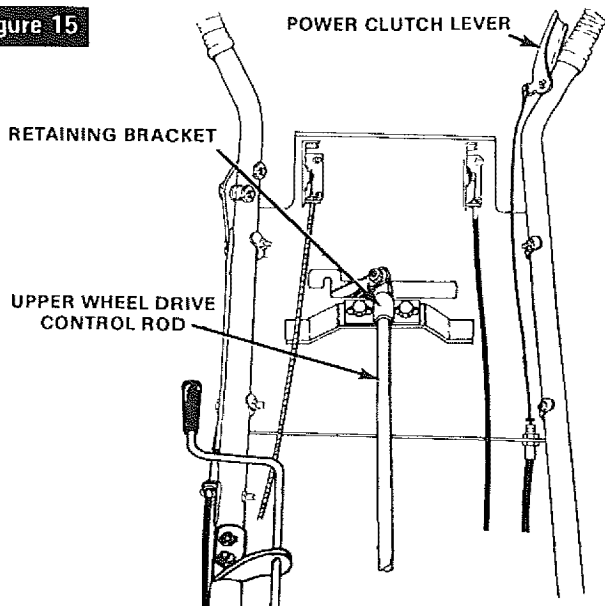

IMPELLER/AUGER CONTROL CABLE ADJUSTMENT

If impeller/auger control should need adjustment because impeller/auger will not engage or will not disengage, adjust as follows:

1. Remove belt cover (figure 11).

Figure 16

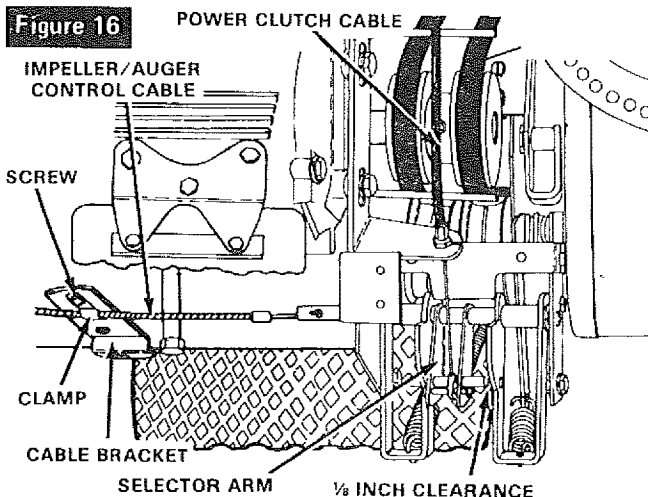

2. Move impeller/auger control lever from OFF to ENGAGE and check action of selector arm (figure 16). When impeller/auger control lever is in ENGAGE position, pin through selector arm should fully engage wheel drive arm and impeller/auger drive arm. When lever is in OFF position,

pin through selector arm should engage wheel drive arm only and clear impeller/auger drive arm by at least $\frac{1}{8}$ inch. To adjust to these positions:

- A. Loosen screw that clamps impeller/auger control cable to cable bracket (figure 16).
- B. Move cable forward or backward in clamp to obtain proper position mentioned above.
- C. Reclamp cable by tightening loosened screw.

⚠ DANGER ⚠

Never attempt to manually stop auger from turning.

CARBURETOR ADJUSTMENT

HIGH SPEED and IDLE ADJUST NEEDLES are pre-set at the factory and re-adjustment should not be necessary. **NOTE:** If you think the carburetor needs adjusting, contact your nearest SEARS Service Center who has the proper equipment and experience to make any necessary adjustments.

⚠ CAUTION ⚠

Never tamper with engine governor which is factory set for proper engine speed. Over-speeding engine above factory high speed setting can be dangerous. If you think the engine governed high speed needs adjusting, contact your nearest SEARS Service Center who has the proper equipment and experience to make any necessary adjustments.

Changing of engine governed speed will void engine warranty.

SPARK PLUG ADJUSTMENT

Check the spark plug periodically and reset spark plug gap to 0.030 inch using a wire feeler gauge.

The condition of the spark plug may be determined by color. A carbonized plug is black and burnt plugs are greyish in color, whereas a normal functioning spark plug is brown. If a new spark plug is required, refer to the Engine Repair Parts section for proper replacement spark plug.

Before installing spark plug, coat threads lightly with graphite grease to insure easy removal.

MAINTENANCE

DRIVE BELT REPLACEMENT

The drive belts on this unit are of special construction and should be replaced with original equipment belts available from your nearest SEARS Store or Service Center.

To Replace Unit Drive Belt (belt nearest engine):

1. Remove belt cover (figure 11).
2. Loosen screw holding left belt guide (figure 12) and swing guide away from pulley. Retighten screw.
3. Loosen screw holding right belt guide (figure 12) and swing guide away from pulley. Retighten screw.
4. Roll belt off engine pulley. **NOTE:** It will be necessary to roll impeller/auger drive belt off engine pulley to allow unit drive belt to be removed from engine pulley.
5. Remove belt by threading up between large drive pulleys.
6. Install new belt in reverse order.

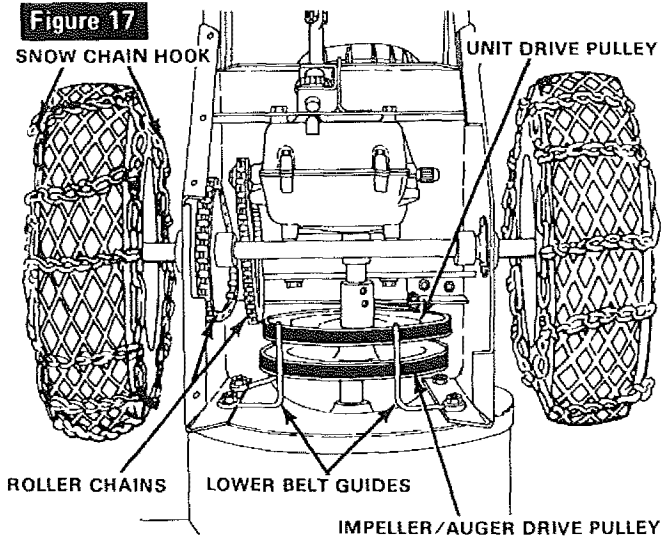

To Replace Impeller/Auger Drive Belt (belt farthest from engine):

1. Remove belt cover (figure 11).
2. Stand unit up on auger end, remove screws from bottom cover and remove cover.
3. Loosen screws holding lower belt guides (figure 17) and swing guides away from belt.
4. Roll belt off impeller/auger drive pulley and engine pulley and remove between drive pulleys.
5. Install new belt in reverse order.
6. Move lower belt guides back to within 1/16 inch of impeller/auger drive pulley and tighten screws.
7. Replace bottom cover and return unit to operating position.
8. Adjust right and left belt guides (figure 12) as instructed in **Step 3** in paragraph **Drive Belt Adjustment** in **Adjustment** section of this manual.
9. Replace belt cover.

SHEAR BOLT REPLACEMENT

The main auger assembly is made up of a right and left auger. Each is secured with a special bolt (figure 18) that acts as a shear bolt. These bolts are designed to break if an object becomes lodged in the auger. Three spare shear bolts and nuts have been furnished with your unit. If additional bolts are required, order genuine replacement bolts. Use of a harder bolt will destroy the protection provided by this special bolt. To replace a broken shear bolt, proceed as follows:

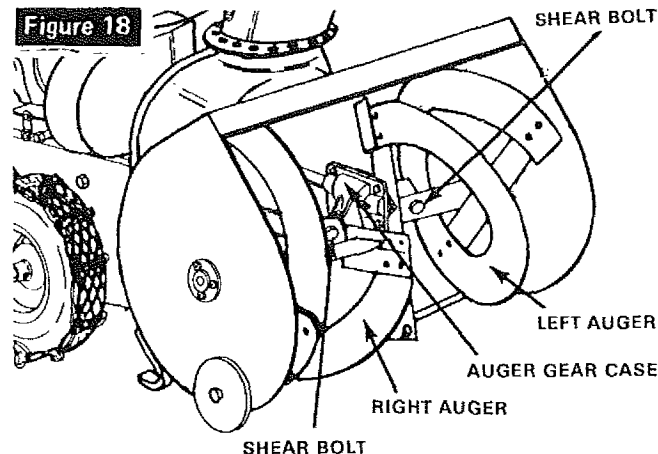

1. Remove the parts of the broken bolt.
2. Align the hole in the auger with the hole in the auger shaft. Install new shear bolt.

ROLLER CHAIN REPLACEMENT

There are two roller chains on this unit as shown in figure 17. Bottom cover will have to be removed to reach chains.

1. Stand unit up on auger end, remove screws from bottom cover and remove cover.
2. Locate master link (figure 19) in chain to be replaced.
3. Check position of open end of keeper link (figure 19) so that replacement link can be installed in the same manner. Open end of keeper link must be in trailing position when chain is operating in direction required for forward motion of unit.
4. Remove master link and remove chain.
5. Install new chain in reverse order of removal.

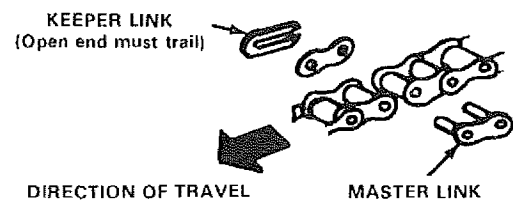

Figure 19

TRANSMISSION REPLACEMENT

The replacement of the transmission on this unit is a major service operation and should be done by a trained technician. The **Transmission Repair Parts** section of this manual contains a list of replacement parts and illustrations to assist the trained technician in making repairs and ordering proper replacement parts.

SNOW CHAIN REMOVAL

To remove the snow chains, release the chain hooks (figure 17). Flatten the chain out on the ground and push unit off the chain. Illustration is the reverse of removal.

LUBRICATION

For lubrication points, frequency of lubrication and type of lubricant, see **Lubrication Chart**.

1. Check crankcase oil level before starting engine and after each 5 hours of continuous use. Add SEARS 5W-30 motor oil or equivalent as required. Change crankcase oil after first 2 hours of operation and every 25 hours of operation thereafter, or at beginning of each season. **NOTE:** SEARS 5W-30 or 10W motor oil (or equivalent) are acceptable substitutes.

To Drain Oil, Proceed as Follows:

- A. Remove oil fill cap and dipstick (figure 20).
- B. Remove oil drain cap (figure 20).
- C. Tip unit toward oil drain cap and drain oil into a suitable container. **NOTE:** Oil will drain more freely when warm.
- D. Replace oil drain cap securely and fill crankcase to proper level shown on dipstick (approximately 1½ pints).

2. Check auger gear case oil level before each use by removing oil level plug as shown in **Lubrication Chart**. Oil should be visible in hole. If oil is required, remove oil fill plug and add SEARS SAE 30 engine oil until oil begins to run out oil level hole. Replace plug and tighten securely.

Figure 20

OIL FILL CAP & DIPSTICK

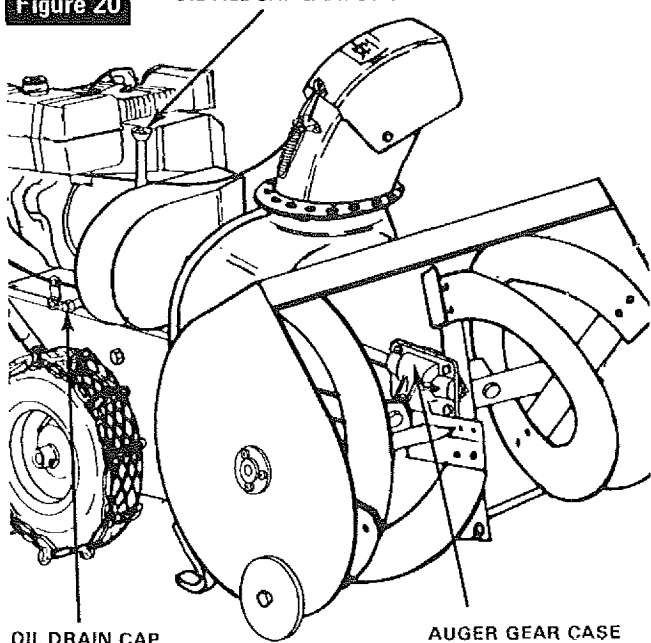

OIL DRAIN CAP

AUGER GEAR CASE

3. The transmission has been factory lubricated for life. If, for some reason, lubricant should leak out, have transmission checked by a competent repairman.

ENGINE SERVICE

Unless the operator is fully qualified to make engine adjustments and repairs, it is recommended that such work be done by technicians trained to work on snow thrower type gasoline engines.

The Engine Repair Parts section of this manual contains a list of engine replacement parts and illustrations to assist the trained technicians in making repairs and ordering proper replacement parts.

STORAGE

The snow thrower should be immediately prepared for storage at the end of the season or if the unit is to be un-used for 30 days or more.

ENGINE STORAGE

DANGER

Never store engine with fuel in tank indoors or in enclosed, poorly ventilated enclosures, where fuel fumes may reach an open flame, spark or pilot light as on a furnace, water heater, clothes dryer, etc.

Gasoline, if permitted to stand un-used for extended periods (30 days or more), may develop gummy deposits which can adversely affect the engine carburetor and cause engine malfunction. To avoid this condition, proceed as follows:

DANGER

Handle gasoline carefully. It is highly flammable and careless use could result in serious fire damage to your person and/or property.

1. Prior to shut down for 30 days or more, and for seasonal storage, drain gasoline from fuel tank.

DANGER

Drain fuel into approved container outdoors, away from open flame.

2. Run engine until fuel tank is empty and engine stops due to lack of fuel.

3. Remove spark plug and pour one (1) ounce of engine oil through spark plug hole into cylinder. Crank engine several times to distribute oil. Replace spark plug.

4. Store unit in wheel down, operating position. If unit is stored in any other position, oil from crankcase could enter cylinder head, causing a service problem.

5. When storing unit at the end of the snow blowing season, service REWIND STARTER as follows:

- A. Remove rewind starter from engine and brush away accumulation of dirt and debris from starter pawl and pawl post (figure 21).
- B. Apply a few drops of engine oil to each pawl post and rotate starter a few times.
- C. Reinstall starter on engine. Be sure the four starter retaining nuts are tightened securely.

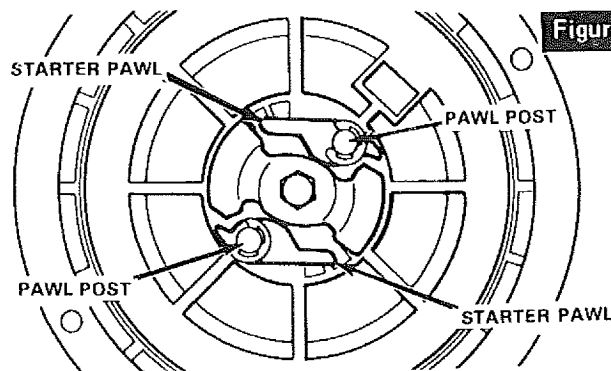

Figure 21

UNIT STORAGE

1. Clean the unit thoroughly; remove all debris and wipe the unit dry.
2. Inspect the snow thrower for worn or damaged parts, tighten all loose hardware.
3. Oil all points described in paragraph **Lubrication**.
4. Store the snow thrower in a protected area and cover the unit for additional protection.

A yearly checkup or tuneup by the SEARS Service Department is a good way of insuring that your snow thrower will provide maximum performance for the next season.

LUBRICATION CHART

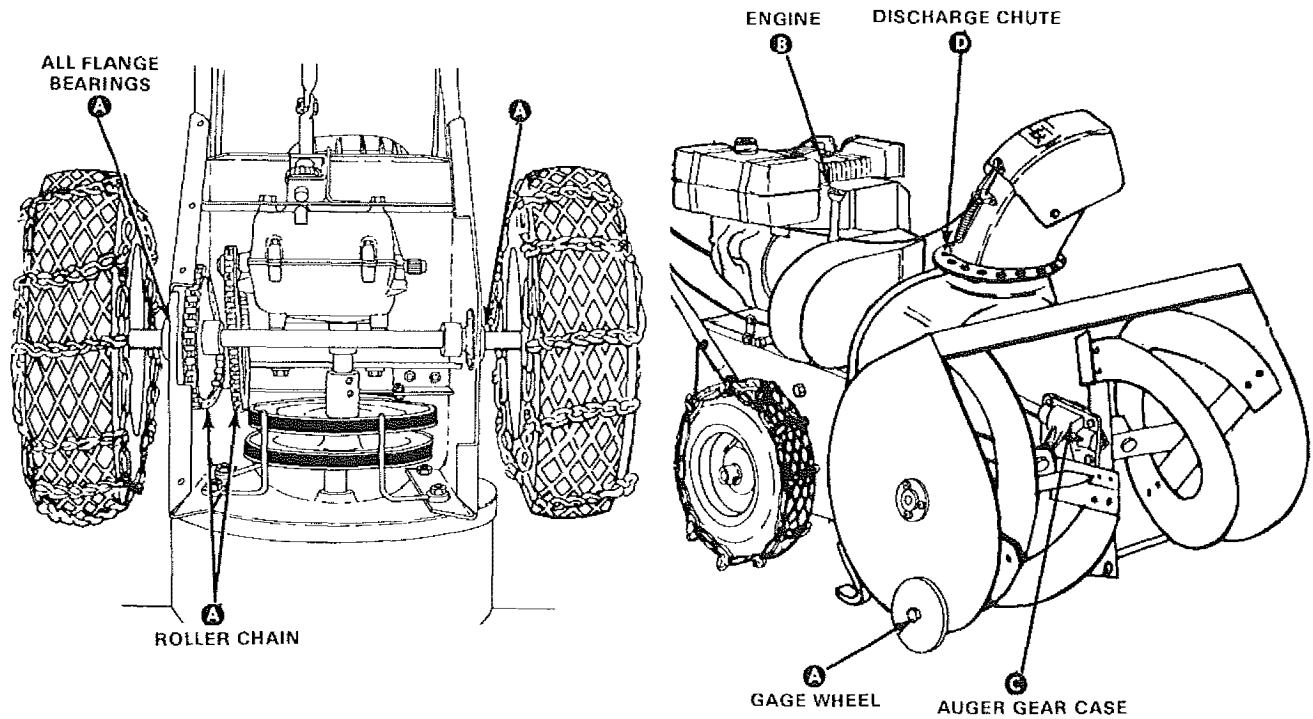

- A** Add Sears S.A.E. 10W oil (or equivalent) every 2 hours and after each use.
- B** Add Sears 5W-20 oil (or equivalent) as required. Check every 5 hours and before each use.
- C** Add Sears S.A.E. 30W oil (or equivalent) as required. Check before each use.
- D** Remove chute and coat with clinging type grease such as lubriplate once each season.

For Service Helps Chart, see page 27.

CRAFTSMAN 24" SNOW THROWER MODEL NUMBER 536.918300

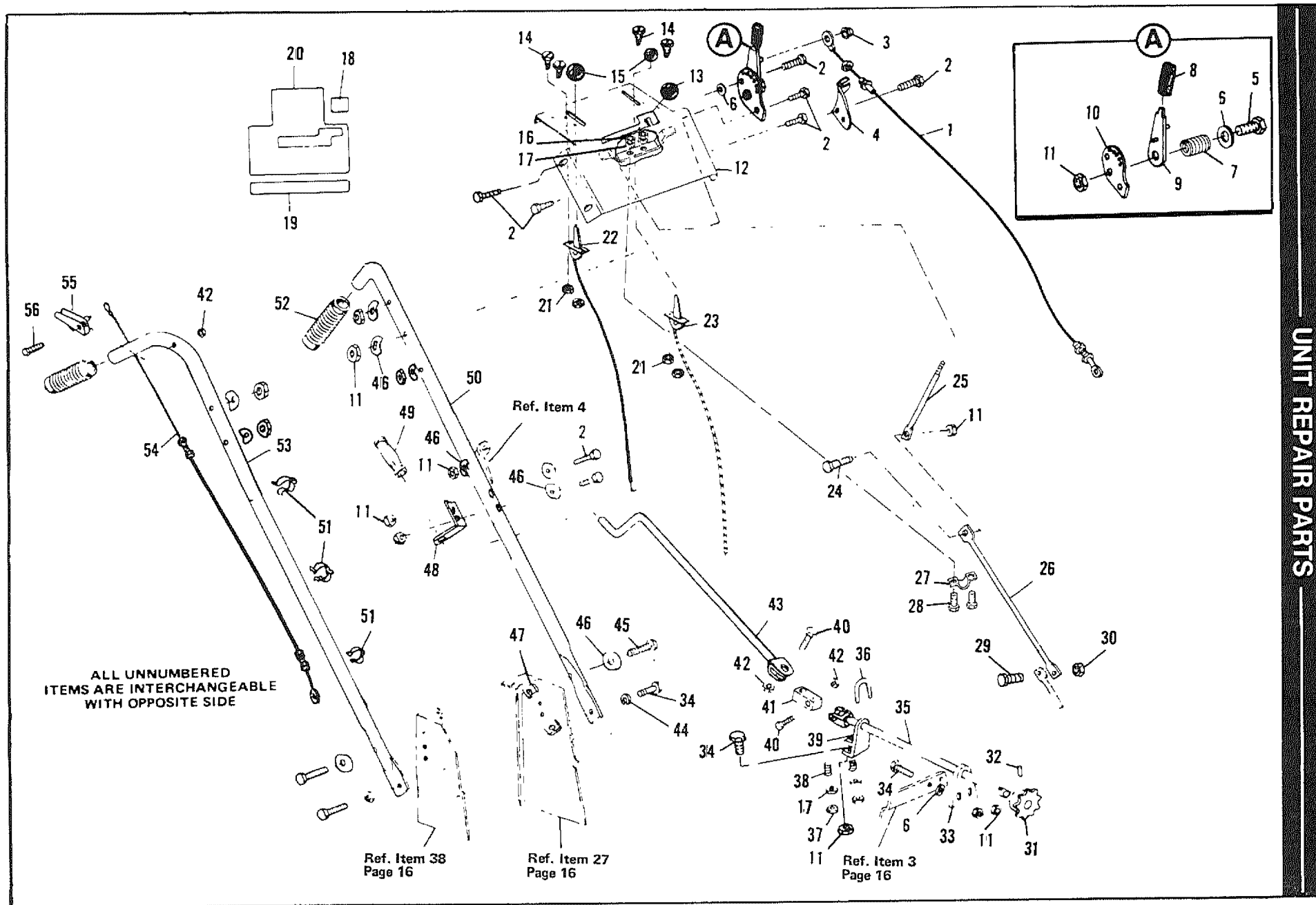

UNIT REPAIR PARTS

CRAFTSMAN 24" SNOW THROWER MODEL NUMBER 536.918300

Key No.	Part No.	Description
1	49551	Cable, Impeller/Auger Control
2	122052	*Screw, Hex Hd, 5/16-18 x 1 3/4 In.
3	49106	Push Nut, 3/16 In.
4	49569	Bracket, Chute Deflector Cable
5	122033	*Screw, Hex Hd, 5/16-18 x 1 3/8 In.
6	996407	*Flatwasher, 5/16 in. I.D.
7	25644	Spring
8	49576	Hand Grip
9	49557	Lever Assembly, Chute Deflector
10	49558	Bracket, Chute Deflector Lever
11	9413447	Locknut, 5/16-18 Thd
12	50168	Panel, Control
13	22822	Knob, Wheel Drive Control Lever
14	443874	*Screw, Hex Hd, No. 10-24 x 1/2 In.
15	50607	Knob, Control Lever
16	997316	Locknut, No. 10-24 Thd
17	9417373	*Flatwasher, No. 10
18	67194	Decal, Chute Control
19	68416	Decal, Craftsman
20	68413	Decal, Control Panel

Key No.	Part No.	Description
21	271166	Locknut, Keps, No. 10-24 Thd
22	50198	Control Assembly, Impeller/Auger
23	50197	Control Assembly, Throttle
24	25494	Shoulder Bolt
25	50393	Lever Assembly, Wheel Drive
26	50146	Rod, Wheel Drive, Upper
27	50152	Retainer Bracket, Wheel Drive Rod
28	9423771	*Screw, Hex Hd, No. 10-24 x 1/2 In.
29	122119	*Screw, Hex Hd, 3/8-16 x 3/4 In.
30	9413534	Locknut, 3/8-16 Thd
31	48395	Sprocket, 9 Tooth
32	455481	*Roll Pin, 3/16 x 1 In.
33	48400	Bracket, Lower Chute Control Rod
34	120228	*Screw, Hex Hd, 5/16-18 x 5/8 In.
35	48399	Rod, Chute Control, Lever
36	23940	U-Bolt
37	997319	Locknut, No. 10-32 Thd
38	23939	Spring

Key No.	Part No.	Description
39	48402	Bracket, Lower Chute Control Rod, Rear
40	180022	*Screw, Hex Hd, 1/4-20 x 1 In.
41	47323	Pivot Block
42	9424215	Locknut, 1/4-20 Thd
43	48405	Rod, Chute Control, Upper
44	120638	*Lockwasher, Split, 5/16 In.
45	122017	*Screw, Hex Hd, 5/16-18 x 1 In.
46	22025	Washer, Formed
47	40631	Nut, Retain
48	48403	Bracket, Upper Chute Control Rod
49	48441	Hand Grip
50	49545	Handle, Left
51	47422	Clamp, Cable
52	48641	Hand Grip
53	49544	Handle, Right
54	49564	Cable, Power Clutch
55	49008	Lever Assembly, Power Clutch
56	133058	*Screw, Rd Hd, 1/4-20 x 3/4 In.
	61817	Owner's Manual (Not Illust.)

*Standard Hardware Items - May Be Purchased Locally.

CRAFTSMAN 24" SNOW THROWER MODEL NUMBER 536.918300

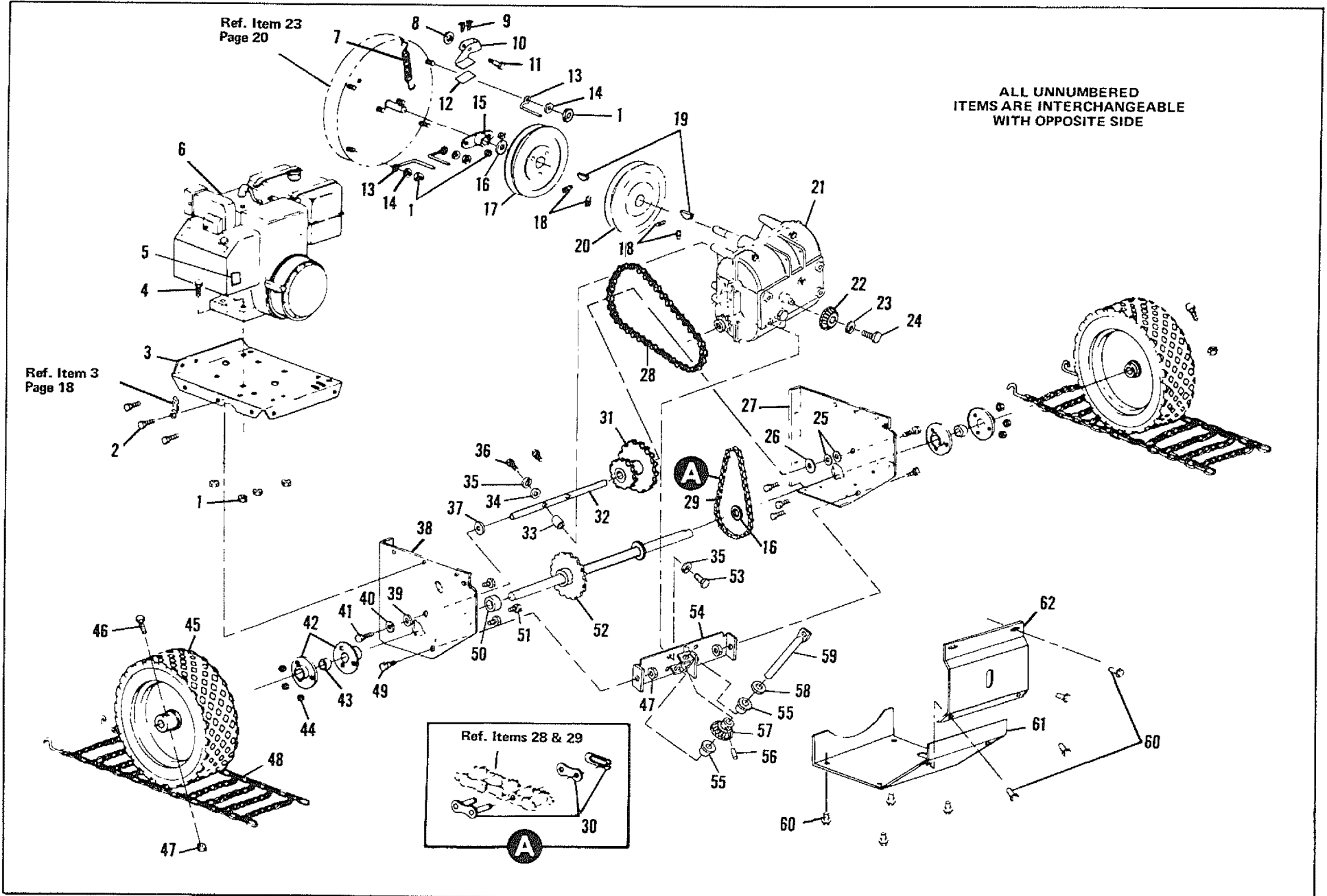

CRAFTSMAN 24" SNOW THROWER MODEL NUMBER 536.918300

Key No.	Part No.	Description	Key No.	Part No.	Description	Key No.	Part No.	Description
1	9413534	Locknut, 3/8-16 Thd	22	50150	Gear, Miter Drive	44	9424215	Locknut, 1/4-20 Thd
2	42619	Screw, Taptite, 3/8-16 x 1/2 In.	23	120380	*Lockwasher, Split, 1/4 In. I.D.	45	48445	Wheel & Tire Assembly
3	49454	Plate, Engine Mount	24	181566	*Screw, Hex Hd, 1/4-28 x 3/4 In.	46	169	*Screw, Hex Hd, 5/16-18 x 1 5/8 In.
4	122119	*Screw, Hex Hd, 3/8-16 x 3/4 In.	25	36625	Ring, Retaining	47	9413447	Locknut, 5/16-18 Thd
5	68423	Decal, Key, On/Off	26	50154	Washer, Thrust	48	20712	Chains, Snow (Set of Two)
6	15316	Engine, Model No. 143.696102 (See Engine Repair Parts List)	27	50170	Side Frame Assembly, Right	49	180075	*Screw, Hex Hd, 5/16-18 x 5/8 In.
7	48422	Spring	28	50641	Roller Chain Assembly	50	41709	Spacer
8	138538	*Lockwasher, Internal Tooth, 5/16 In. I.D.	29	50640	Roller Chain Assembly	51	36602	*Bolt, Carriage, 1/4-20 x 5/8 In.
9	35055	Screw, Taptite, No. 10-24 x 1/2 In.	30	20307	Link, Connector	52	50624	Axle & Sprocket Assembly
10	48424	Bracket, Brake	31	50542	Sprocket & Bearing Assembly	53	35498	Screw, Hex Washer Hd Tap, 5/16-18 x 3/4 In.
11	41727	Shoulder Bolt	32	50155	Shaft, Intermediate	54	50163	Plate Assembly, Transmission Mounting
12	49577	Pad, Brake	33	50149	Spacer	55	50148	Bearing, Flanged
13	49530	Belt Guide, Lower	34	996407	*Flatwasher, 5/16 In. I.D.	56	454512	Pin, Spring, 3/16 x 3/4 In.
14	274517	*Flatwasher, 3/8 In. I.D.	35	120638	*Lockwasher, Split, 5/16 In. I.D.	57	50151	Gear Miter Driver
15	40616	Bearing, Impeller	36	180087	Screw, Hex Hd, 5/16-18 x 2 In.	58	39024	Flatwasher, 1/2 In. I.D.
16	25177	*Flatwasher, 3/4 In. I.D.	37	50153	Washer, Thrust	59	50147	Rod, Wheel Drive, Lower
17	48388	Pulley, Impeller/Auger	38	50169	Side Frame Assembly, Left	60	35144	Screw, Hex Hd Slotted Taptite, No. 10-24 x 3/8 In.
18	102883	*Set Screw, 5/16-18 x 3/4 In.	39	41891	Washer, Bow	61	50166	Cover, Bottom
19	27324	Key, Hi-Pro, No. 606	40	138485	*Lockwasher, External Tooth, 5/16 In. I.D.	62	50164	Cover, Rear
20	50158	Pulley, Transmission	41	41890	Shoulder Bolt			
21	50171	Transmission, Model No. 143.735 (See Transmission Repair Parts List)	42	25072	Disc, Bearing Retainer			
			43	48666	Bearing, Self-Aligning			

*Standard Hardware Items - May Be Purchased Locally.

CRAFTSMAN 24" SNOW THROWER MODEL NUMBER 536.918300

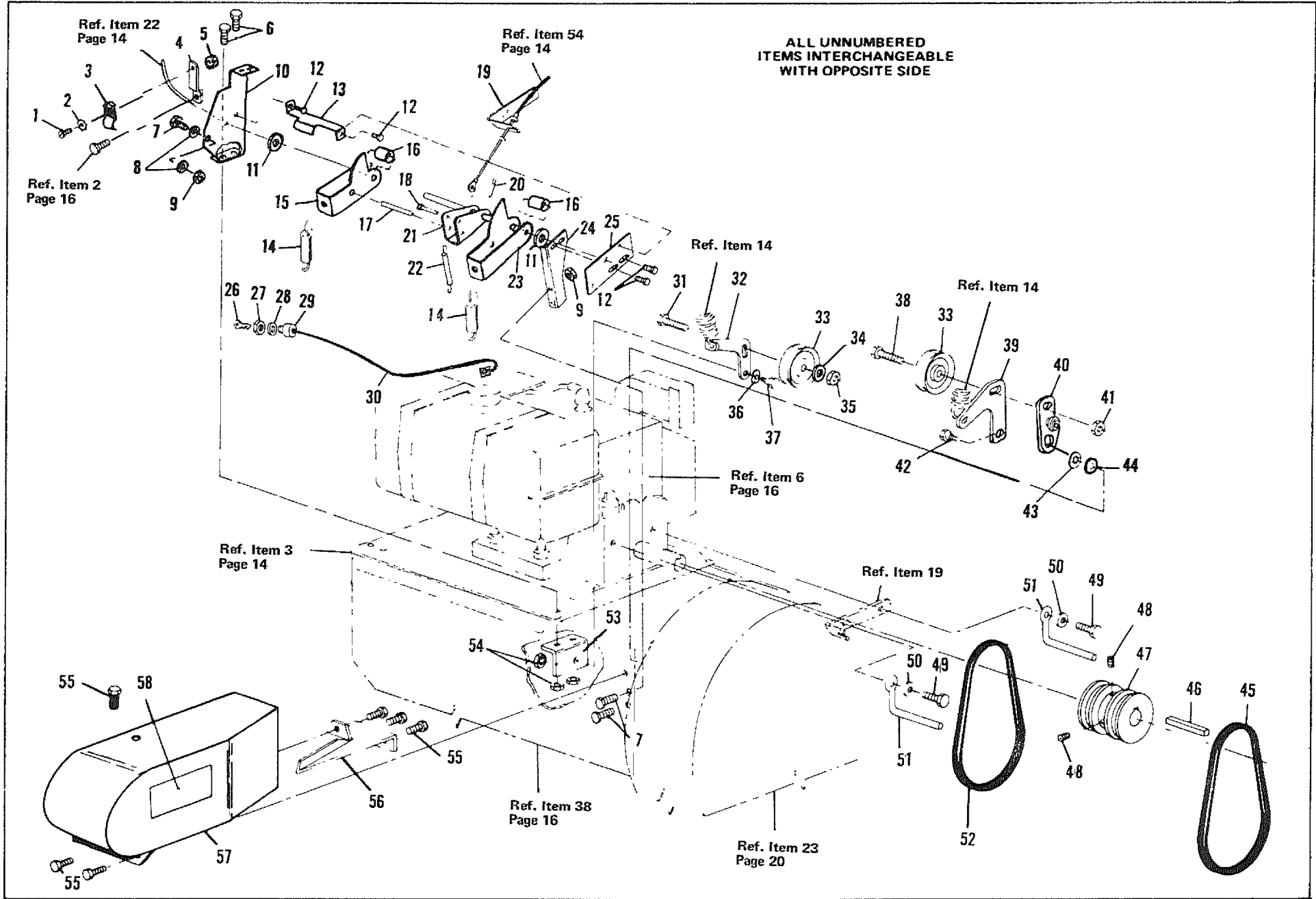

CRAFTSMAN 24" SNOW THROWER MODEL NUMBER 536.918300

Key No.	Part No.	Description
1	159920	Screw, No. 10-24 x 1/2 In.
2	138479	Lockwasher, External Tooth
3	41652	Clip, Wire
4	49012	Bracket, Impeller/Auger Cable
5	271166	Nut, Keps, No. 10-24 Thd
6	120228	*Screw, Hex Hd, 5/16-18 x 3/8 In.
7	180016	Screw, Hex Hd, 1/4-20 x 1/2 In.
8	120380	Lockwasher, Split
9	9424215	Locknut, 1/4-20 Thd
10	48994	Plate, Idler Mount
11	120394	Washer
12	40886	Screw, Taptite, Hex Washer Hd, 1/4-20 x 3/8 In.
13	49018	Brace
14	49527	Spring, Idler
15	49010	Arm, Wheel Drive
16	49531	Spacer
17	456836	Pin, 1/4 x 2 1/4 In.
18	49014	Clevis Pin
19	48991	Bracket, Power Clutch Cable

Key No.	Part No.	Description
20	121223	Cotter Pin, 1/16 x 3/4 In.
21	49019	Selector Assy
22	24347	Spring
23	49009	Arm, Impeller/Auger Drive
24	49016	Bracket, Mounting
25	49017	Plate
26	36285	Key, Ignition
27	48140	Locknut (Switch Part)
28	138557	Lockwasher (Switch Part)
29	46376	Switch (Incl. Items 26, 27 & 28)
30	47410	Wire Assembly, Ignition
31	45892	Carriage Bolt, 3/8-16 x 1 1/2 In.
32	49504	Idler Arm, Primary
33	50610	Pulley, Idler
34	120382	Lockwasher, Split 3/8 In.
35	124829	Nut, Hex Jam, 3/8-16 Thd
36	3140	Washer, Wave
37	46511	Bolt, Shoulder
38	120918	Screw, Hex Hd, 3/8-16 x 1 1/2 In.
39	49505	Idler Arm, Auger

Key No.	Part No.	Description
40	50608	Roller Arm Assembly
41	9413534	*Locknut, 3/8-16 Thd
42	41727	Bolt Shoulder
43	138538	Lockwasher, Internal Tooth
44	41728	Spacer
45	49581	V-Belt
46	26794	Key, Square, 1/4 x 1 1/2 In.
47	44917	Pulley, Engine
48	998503	*Set Screw, 5/16-18 x 1/4 In.
49	120741	*Screw, Hex Hd, 5/16-24 x 3/4 In.
50	120638	*Lockwasher, Split, 5/16 I.D.
51	49822	Belt Guide, L.H.
52	49570	V-Belt
53	48999	Mounting Bracket Auxiliary
54	9413447	*Locknut, 5/16-18 Thd
55	35144	Screw, Slotted Hex Hd, Taptite, 10-24 x 3/8 In.
56	46161	Extension, Belt Cover
57	48534	Cover, Belt
58	68415	Decal

*Standard Hardware Items - May Be Purchased Locally.

CRAFTSMAN 24" SNOW THROWER MODEL NUMBER 536.918300

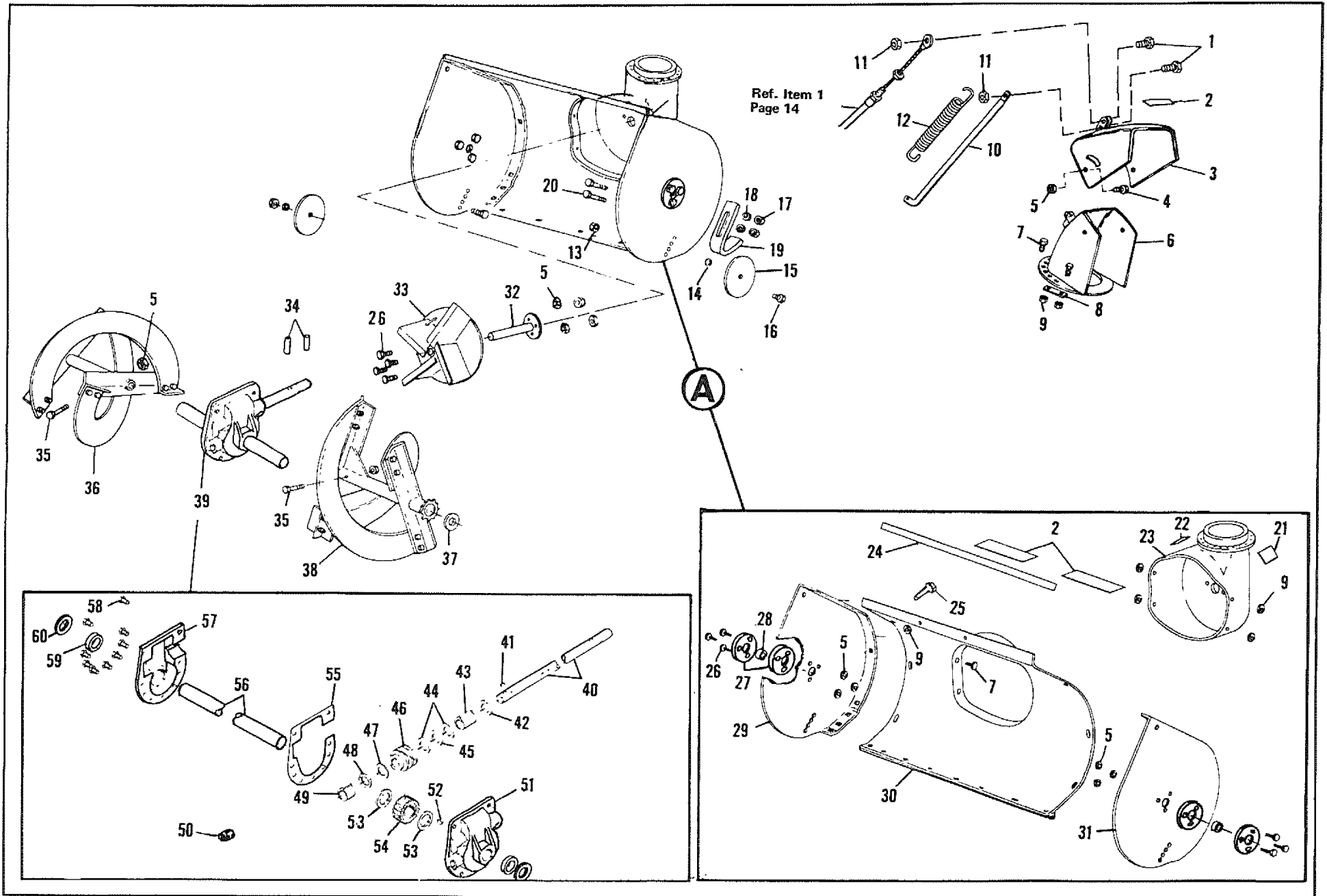

CRAFTSMAN 24" SNOW THROWER MODEL NUMBER 536.918300

Key No.	Part No.	Description
1	49573	Screw, Hex Hd, No. 10-24 x 5/8 In.
2	67173	Decal, Caution
3	49560	Chute Assembly, Top
4	120834	*Screw, Hex Hd, 5/16-18 x 3/4 In.
5	9413447	Locknut, 5/16-18 Thd, Type N
6	49550	Chute Assembly, Bottom
7	180016	*Screw, Hex Hd, 1/4-20 x 1/2 In.
8	47240	Chute Clip
9	9424215	Locknut, Hex, 1/4-20 Thd, Type N
10	49555	Chute Rod
11	997316	Locknut, No. 10-24 Thd
12	49552	Spring
13	9413534	Locknut, 3/8-16 Thd
14	274517	*Flatwasher, 3/8 ID
15	27318	Gage Wheel Assembly
16	39119	Shoulder Bolt
17	271184	*Nut, Keps, 5/16-18
18	446363	*Flatwasher, 5/16 ID
19	25091	Skid
20	126358	Carriage Bolt, 5/16-18 x 1 In.
21	67680	Decal, Caution

Key No.	Part No.	Description
22	68183	Decal, Caution
23	47238	Cover Assembly, Impeller
24	67167	Decal, Name
25	36602	Carriage Bolt, 1/4-20 x 5/8 In.
26	180077	*Screw, Hex Hd, 5/16-18 x 3/4 In.
27	48209	Bearing, Retainer
28	48210	Bearing, Self-Aligning
29	48216	Auger Housing End, R.H.
30	48459	Auger Cover & Scraper Assembly
31	48217	Auger Housing End, L.H.
32	48606	Impeller Shaft, Assembly
33	47256	Impeller Assembly
34	454565	Roll Pin, 1/4 x 1 1/4 In.
35	13322	Shear Bolt
36	48768	Auger Assembly, R.H.
37	21970	*Washer, 1 ID x 3/4 OD x .125 Thk
38	48767	Auger Assembly, L.H.
39	48264	Gear Case Assembly
40	48352	Shaft, Gear Box, Long
41	3021	*Key, Woodruff, No. 9
42	24274	Oil Seal

Key No.	Part No.	Description
43	48274	Bearing
44	48275	Washer, Thrust
45	32397	Bearing, Needle
46	47787	Worm Gear
47	21682	Spring Washer
48	21681	Ring, Retaining
49	48273	Bearing, Input, Front
50	23700	Pipe Plug
51	48265	Gear Case Assy, L.H. (Incl. Items 59 & 60)
52	21684	*Key, Hi-Pro
53	48271	Washer, Thrust
54	47801	Gear, Bronze
55	48270	Gasket, Gear Case
56	48272	Shaft, Gear Box, Short
57	48266	Gear Case Assy, R.H. (Incl. Items 59 & 60)
58	35498	Screw, Taptite, 5/16-18 x 3/4 In.
59	48269	Bearing
60	21922	Oil Seal

*Standard Hardware Items - May Be Purchased Locally.

CRAFTSMAN 4-CYCLE ENGINE MODEL NUMBER 143.696102

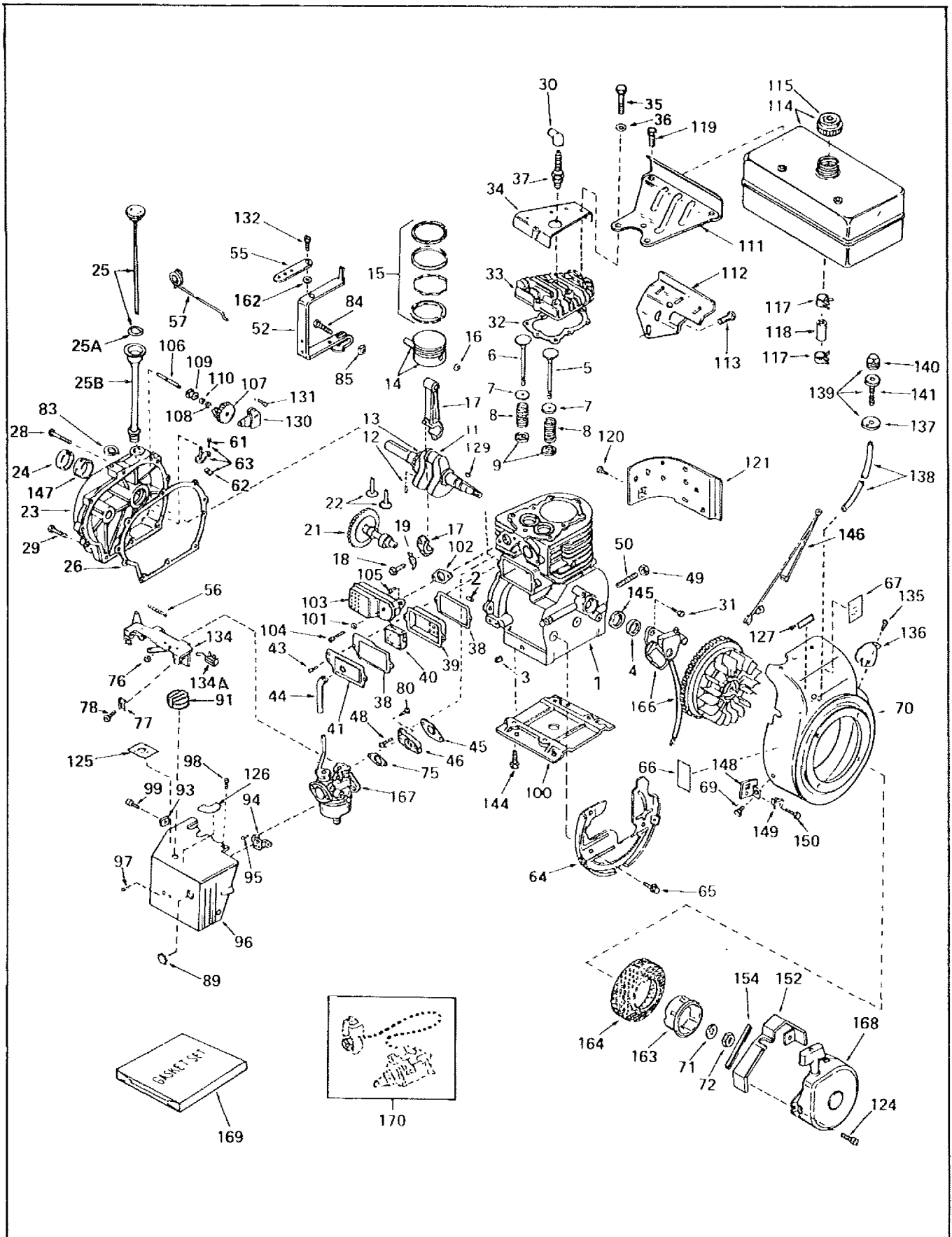

CRAFTSMAN 4-CYCLE ENGINE MODEL NUMBER 143.696102

Ref. No.	Part No.	Part Name	Ref. No.	Part No.	Part Name
1	32586B	Cylinder Assy. (Incl. Nos. 2, 3 & 4)	55	30205	Bracket, Governor adjusting
2	27652	Pin, Dowel	56	30826	Spring, Extension
3	27642	Plug, Sq. hd. pipe (Oil drain)	57	30824	Link, Governor-to-throttle
4	32630	Seal, Oil	61	650494	Screw, Fil. hd. Sems, 6-40 x 5/16
5	32783	Valve, Intake (Std.) (Incl. No. 9)	62	30700	Yoke, Governor
5	32784	Valve, Intake (1/32" oversize) (Incl. No. 9)	63	30699C	Rod Assy. Governor (Incl. Nos. 61 & 62)
6	27878A	Valve, Exhaust (Std.) (Incl. No. 9)	64	29536	Baffle, Blower housing
6	27880A	Valve, Exhaust (1/32" oversize) (Incl. No. 9)	65	650561	Screw, Hex washer hd. durlock, 1/4-20 x 5/8
7	27882	Cap, Upper valve spring	66	34374	Decal, Instruction
8	27881	Spring, Valve	67	34170	Decal, Instruction
9	32581	Cap, Lower valve spring	69	29747A	Screw, Hex hd. Sems, 5/16-24 x 3/4
11	32680A	Crankshaft Assy. (Incl. Nos. 12 & 13)	70	32158B	Housing, Blower (Incl. Nos. 135 & 136)
12	29783	Pin, Crankshaft gear	71	650490	Washer, Belleville
13	27884	Gear, Crankshaft	72	8116	Nut, Crankshaft
14	33592B	Piston & Pin Assy. (Incl. No. 16) (Std.)	75	*31688	Gasket, Carburetor
14	33593B	Piston & Pin Assy. (Incl. No. 16) (.010 oversize)	76	29752	Nut & Lockwasher Assy., 1/4-28
14	33594B	Piston & Pin Assy. (Incl. No. 16) (.020 oversize)	77	27793	Clip, Conduit
14	34517	Piston, Pin & Ring Assy. (Incl. Nos. 15 & 16) (Std.)	78	28942	Screw, Hex washer hd. Sems, 10-32 x 3/8
14	34518	Piston, Pin & Ring Assy. (Incl. Nos. 15 & 16) (.010 oversize)	80	650572	Screw, Flat hd. Sems, 1/4-28 x 1-1/8
14	34519	Piston, Pin & Ring Assy. (Incl. Nos. 15 & 16) (.020 oversize)	83	29642	Ring, Retaining
15	32595	Ring Set, Piston (Std.)	84	29826	Screw, Hex washer hd., 10-32 x 3/4
15	32596	Ring Set, Piston (.010 oversize)	85	29216	Locknut, Hex, 10-32
15	32597	Ring Set, Piston (.020 oversize)	89	31291	Plug, Cover
16	27888	Ring, Piston pin retaining	91	34585	Knob, Control
17	32591C	Rod Assy., Connecting (Incl. Nos. 18 & 19)	93	650764	Nut, "U" Type
18	650662A	Screw, Connecting rod	94	32398	Bracket, Carburetor cover
19	34242	Dipper, Oil	95	28820	Screw, Fil. hd. Sems, 10-32 x 1/2
21	32115	Camshaft (Mech. Compression Release)	96	34581	Cover, Carburetor
22	34034	Lifter, Valve	97	650257	Screw, Pan hd. Sems, 8-32 x 5/16
23	31303B	Cover, Cylinder (Incl. Nos. 24, 106 & 147)	98	650765	Screw, Hex washer hd. self-drilling, 10-32 x 1/2
24	28427	Seal, Oil	99	650760	Screw, Pan hd. taptite, 8-32 x 7/16
25	34011A	Dipstick, Oil (Incl. No. 25A)	100	29538	Base, Engine mounting
25A	33590	"O" Ring	101	26073	Washer, Flat
25B	33893A	Tube, Oil filler	102	*27930	Gasket, Muffler
26	*30684	Gasket, Cylinder cover	103	32401	Muffler
28	650488	Screw, Hex hd. Sems, 1/4-20 x 1-1/4	104	650694A	Screw, Hex flange hd., 5/16-18 x 2
29	650493	Screw, Hex hd. Sems, 1/4-20 x 1-3/4	105	30196	Screw, Fil. hd., 5/16-18 x 3/4
30	610118	Cover, Spark plug	106	31845	Shaft, Mechanical governor
31	650489	Screw, Hex hd. Sems, 1/4-20 x 5/8	107	30591	Gear Assy., Governor (Incl. No. 110)
32	*32631	Gasket, Cylinder head	108	29193	Ring, Retaining
33	30938A	Head, Cylinder	109	30588A	Spool, Governor
34	30939A	Cover, Cylinder head	110	30590A	Washer, Flat
35	650697A	Screw, Hex flange hd., 5/16-18 x 2-1/2	111	34159	Plate, Fuel tank mounting
36	650691	Washer, Flat	112	34158	Bracket, Fuel tank mounting
37	33636	Plug, Spark (Champion J-8 or equivalent) <u>Except for Canada</u>	113	650561	Screw, Hex washer hd. durlock, 1/4-20 x 5/8
37	34251	Resistor Spark Plug (Canadian Regulations require RJ-17LM resistor spark plug)	114	34186	Tank Assy., Fuel (Incl. No. 115)
38	*27896	Gasket, Valve spring cover	115	30998B	Cap, Fuel
39	28423	Body Assy., Breather	117	26460	Clamp, Fuel line
40	28424	Element, Breather	118	30962	Line, Fuel
41	28425	Cover, Valve spring	119	650665	Screw, Hex washer hd. Sems, self-tap, 1/4-14 x 7/8
43	650128	Screw, Fil. hd. Sems, 10-24 x 1/2	120	650128	Screw, Fil. hd. Sems, 10-24 x 1/2
44	27627	Tube, Breather	121	30622	Extension, Blower housing
45	*27915	Gasket, Intake	124	29716	Screw, Pan hd. Sems, 1/4-28 x 7/16
46	30195A	Flange, Carburetor (Incl. Nos. 77 & 80)	125	34129	Decal, Warning
48	30196	Screw, Fil. hd. Sems, 5/16-18 x 3/4	126	34133	Decal, Choke
49	30969	Cap, Oil drain	127	34144	Decal, "Primer"
50	32678	Nipple, Pipe	129	32589	Key, Flywheel
52	32326A	Lever, Governor	130	31843A	Bracket, Governor gear
			131	28763	Screw, Hex washer hd., shakeproof, 10-32 x 19/32
			132	650548	Screw, Hex washer hd., 8-32 x 5/16

*Indicates Parts Included in Gasket Set, Ref. No. 169.

CRAFTSMAN 4-CYCLE ENGINE MODEL NUMBER 143.696102

Ref. No.	Part No.	Part Name	Ref. No.	Part No.	Part Name
134	33108A	Control Assy., Remote speed (Incl. Nos. 56 & 134A)	154	32576	Seal, Snow guard
134A	610973	Terminal Assy.	162	29918	Lockwasher, No. 8 E.T.
135	650736	Screw, Pan hd., 10-16 x 3/8	163	32125	Cup, Starter
136	33013	Cover, Starter bubble	164	590417	Screen, Starter cup
137	32312	Retainer, Primer bulb	166	610694A	Magneto (The complete magneto is not available as an assembly. The magneto number is shown for reference purposes only. Order component parts individually, as shown in parts list.)
138	32180A	Line, Primer			
139	32182	Primer Asy. (Incl. Nos. 137, 140 & 141)			
140	32183	Bulb, Primer			
141	32184	Body, Primer			
144	650542	Screw, Hex hd., 5/16-18 x 3/4	167	631920	Carburetor (Incl. No. 75)
145	33876	Gasket, Stator	168	590473	Starter Assy., Rewind
146	34240	Wire, Ground	169	33239	Gasket Set (Incl. items marked *)
147	31546	Bushing, Crankshaft	170		Electric Starter Kit No. 143.88902 (Optional)
148	34126	Bracket, Grommet mounting			
149	28545	Grommet, Plastic			
150	650643	Screw, Pan hd. self-tap, 8-18 x 3/8			
152	34127	Guard, Starter			

*Indicates Parts Included in Gasket Set, Ref. No. 169.

MAGNETO NUMBER 610694A

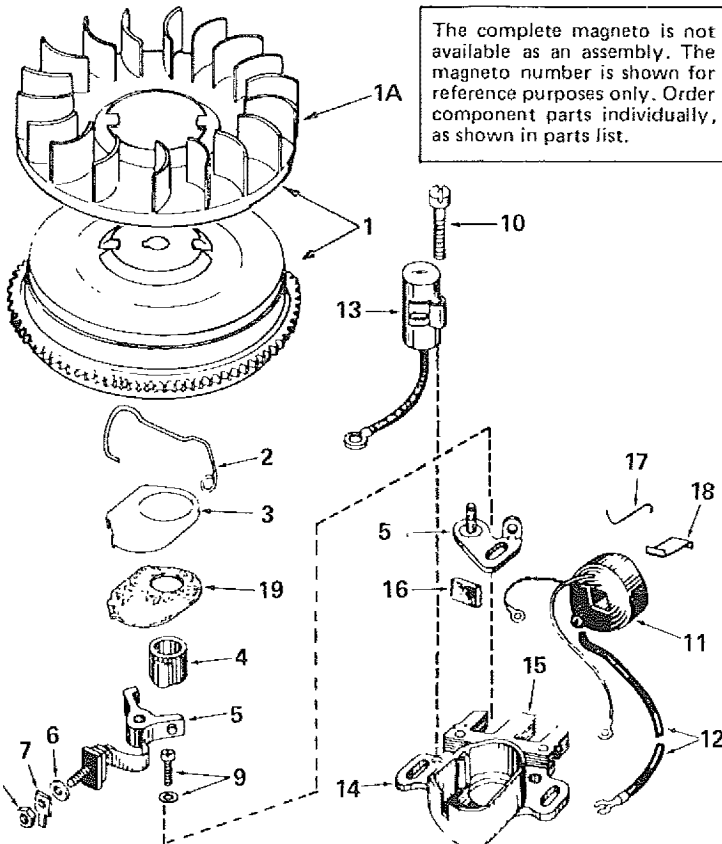

Ref. No.	Part No.	Part Name
	610694A	Magneto
1	30811A	Flywheel (Incl. No. 1A)
1A	610934	Fan
2	30551	Spring, Breaker box dust cover
3	610947	Cover, Dust
4	30992	Cam, Breaker
5	30547A	Contact Assembly, Breaker
6	610385	Washer, Terminal
7	33356	Tab, Ground terminal
8	610408	Nut, Terminal
9	29181	Screw & Washer, Breaker
10	610593	Screw, Condenser
11	30560A	Coil Assy. (Incl. No. 12)
12	30554	Wire, Lead
13	30548B	Condenser
14	30545	Core & Plate
15	30561B	Stator Assy. (Incl. Nos. 2, 3, 5 thru 14 & 16 thru 19)
16	30549	Felt, Cam wiper
17	31311	Clip, Coil locking
18	29629	Spring, Coil wedge
19	610955	Gasket, Dust cover
19	610956	Gasket, Dust cover

CARBURETOR NUMBER 631920

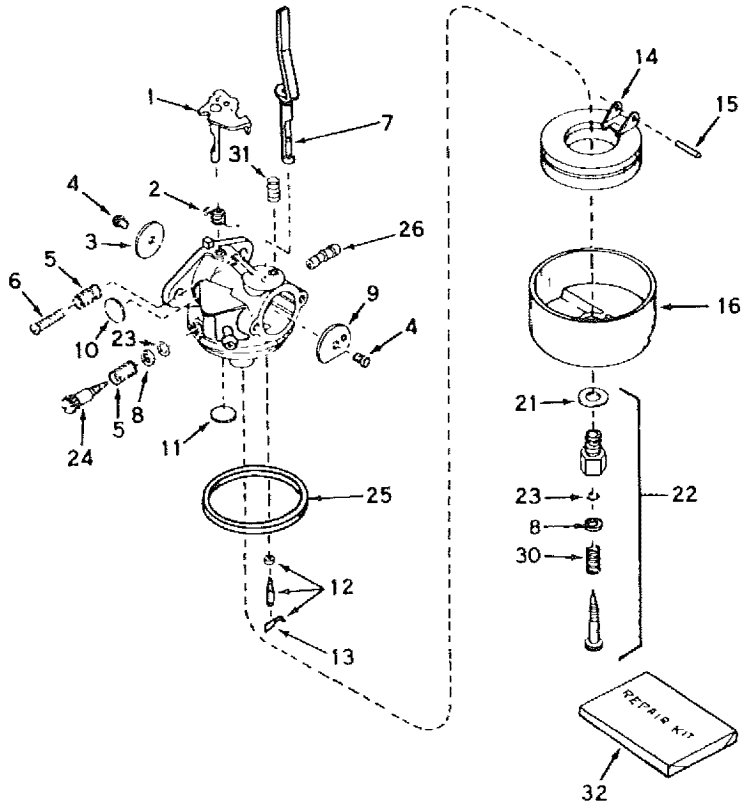

Ref. No.	Part No.	Part Name
	631920	Carburetor
1	31834	Shaft & Lever Assy., Throttle
2	632016	Spring, Throttle return
3	631036	Shutter, Throttle
4	650506	Screw, 4-40 x 3/16
5	630766	Spring, Idle regulating screw
6	650417	Screw, Idle regulating
7	631913	Shaft & Lever Assy., Choke
8	630739	Washer, Flat
9	631815	Shutter, Choke
10	*630748	Plug, Welch
11	*631027	Plug, Welch
12	*631021	Inlet Needle, Seat & Clip Assy. (Incl. No. 13)
13	631022	Clip, Inlet needle
14	632019	Float, Carburetor
15	*631024	Shaft, Float
16	631867	Bowl, Float
21	27110	Gasket, Bowl-to-body
22	*31839	Adjustment Screw Assy., Main (Incl. Nos. 8, 21, 23 & 30)
23	*630740	"O" Ring, Adjustment screw
24	*631078	Screw, Idle adjustment
25	*631028	Gasket, Bowl-to-body
26	631803	Fitting, Fuel inlet
30	630738	Spring, Main Adjustment screw
31	630735	Spring, Choke stop
32	31840	Repair Kit (Incl. items marked *)

REWIND STARTER NUMBER 590473

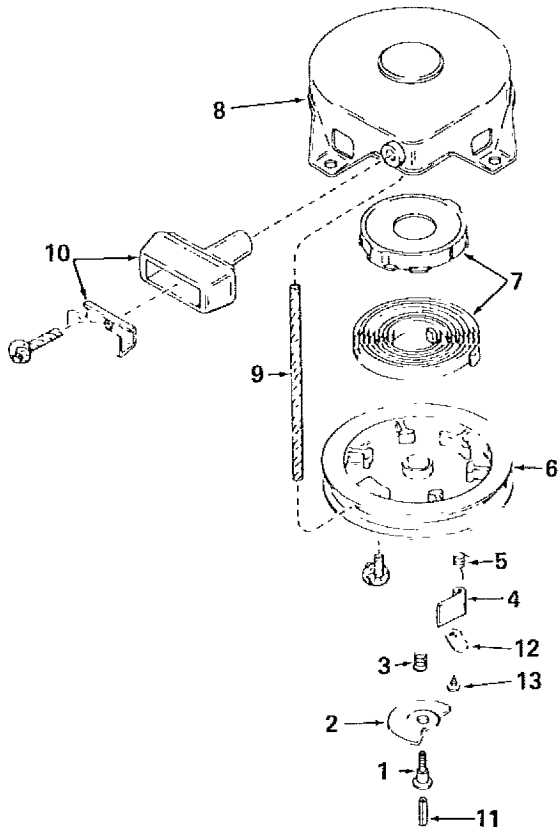

Ref. No.	Part No.	Part Name
	590473	Starter, Rewind
1	590409A	Screw, Retainer
2	590474	Cam, Dog
3	590411	Spring, Brake
4	590148	Dog, Starter
5	590475	Spring, Dog
6	590478	Pulley
7	590414	Spring & Keeper Assy.
8	590415	Housing Assy., Starter (Incl. No. 1)
9	590451A	Rope, Starter
10	590387	Handle Assy., Starter
11	590459	Pin, Centering
12	590476	Retainer, Dog
13	590477	Screw, No. 6 x 5/16

TRANSMISSION REPAIR PARTS

5 SPEED TRANSMISSION MODEL NUMBER 143.735

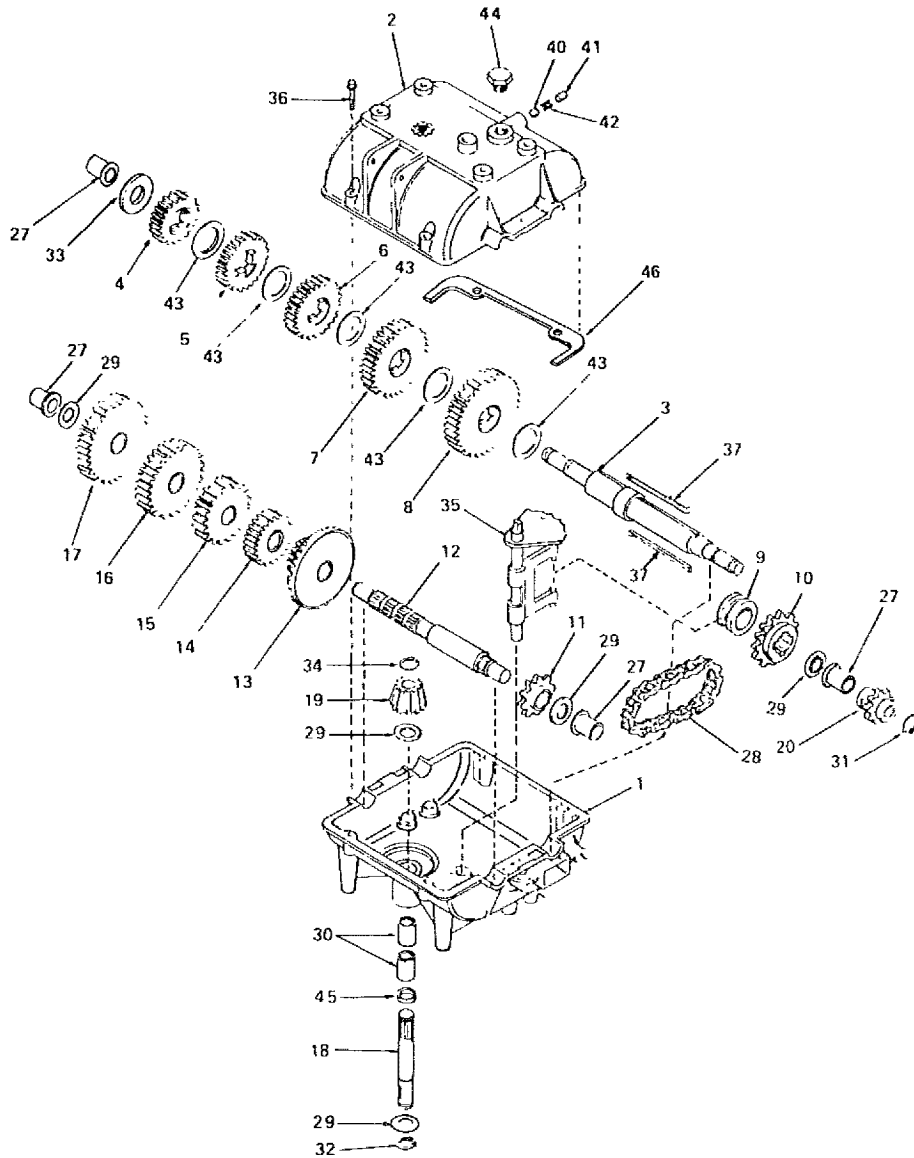

Ref. No.	Part No.	Part Name	Ref. No.	Part No.	Part Name
	794254	Complete Transmission	19	778113	Bevel pinion, Input
1	770061	Case, Transmission	20	786049	Sprocket (8 teeth)
2	772070	Cover, Transmission	27	780105	Bushing, Flanged
3	776161	Shaft, Output	28	786062	Chain, Roller (No. 41 chain, 22 links)
4	778121A	Gear, Spur (20 teeth)	29	780072	Race, Thrust
5	778122	Gear, Spur (22 teeth)	30	780086	Bearing, Needle
6	778123	Gear, Spur (25 teeth)	31	792072	Ring, Retaining
7	778124	Gear, Spur (30 teeth)	32	792035	Ring, Retaining
8	778125	Gear, Spur (35 teeth)	33	780109	Washer
9	784266	Collar, Shift	34	788040	Ring, Retaining
10	786060	Sprocket (14 teeth)	35	784267	Rod & Fork Assy., Shift
11	786061	Sprocket (10 teeth)	36	792073	Screw, Hex hd. tap-tite, 1/4-20 x 1-1/4
12	776134	Shaft, Counter	37	792089A	Key
13	778109	Gear, Bevel (42 teeth & 15 tooth spur gear)	40	792077	Ball, Steel, 5/16
14	778126	Gear, Spur (20 teeth)	41	792078	Screw, Set, 3/8-16 x 3/8
15	778127	Gear, Spur (25 teeth)	42	792079	Spring
16	778128	Gear, Spur (28 teeth)	43	780108	Washer, Thrust
17	778129	Gear, Spur (30 teeth)	44	792074	Plug
18	776143	Shaft, Input	45	792001	Ring, Square cut
			46	788054	Gasket

SERVICE HELPS

DANGER: ALWAYS DISCONNECT SPARK PLUG BEFORE ATTEMPTING ANY REMEDY!

TROUBLE	LOOK FOR	REMEDY
Difficult starting, Engine runs erratic	Defective spark plug	Replace defective plug.
	Blocked fuel line or empty gas tank	Clean fuel line; check fuel supply.
	Review paragraph To Start Engine .	
Engine stalls; Loss of power; Engine runs erratic	Unit running on CHOKE	Set choke lever to RUN position.
	Obstruction in impeller housing	Remove obstruction; clean impeller housing. Refer to Danger after Step 6 of Snow Thrower Operation paragraph in Operation section of this manual.
	Water in fuel system	Remove carburetor bowl to drain fuel tank. Refill with fresh fuel
	CAUTION: Do not remove carburetor bowl when the engine is hot.	
Excessive vibration	Loose parts; Damaged impeller	Stop engine immediately; tighten all bolts and make all necessary repairs. If vibration continues, have the unit serviced by a competent repairman.
Unit fails to propel itself	Drive belt loose or defective	Replace drive belt. Refer to Drive Belt Replacement paragraph in Maintenance section of this manual.
	Broken shear bolt	Replace shear bolt. Refer to Shear Bolt Replacement paragraph in Maintenance section of this manual.
	Drive roller chain defective	Replace roller chain. Refer to Roller Chain Replacement paragraph in Maintenance section of this manual.
	Unit drive belt loose or defective	Adjust unit drive belt; replace if defective. Refer to Drive Belt Adjustment paragraph in Adjustment section or Drive Belt Replacement paragraph in Maintenance section of this manual.
Unit fails to discharge snow	Impeller drive belt loose or defective	Adjust impeller/auger drive belt; replace if defective. Refer to Drive Belt Adjustment paragraph in Adjustment section or Drive Belt Replacement paragraph in Maintenance section of this manual.
	Impeller/Auger control out of adjustment	Adjust impeller/auger control cable. Refer to Impeller/Auger Control Cable Adjustment paragraph in Adjustment section of this manual.
	Shear bolt broken	Replace shear bolt. Refer to Shear Bolt Replacement paragraph in Maintenance section of this manual.
	Discharge chute clogged	Clean discharge chute and inside of auger housing. Refer to Danger after Step 6 of Snow Thrower Operation paragraph in Operation section of this manual.
	Foreign object lodged in auger	Remove object from auger. Refer to Danger after Step 6 of Snow Thrower Operation paragraph in Operation section of this manual.
	Auger gear case trouble	Check auger gear case for broken or bound parts and for oil level. See Unit Repair Parts section of this manual for correct order of parts.
	Transmission trouble	Have transmission checked by competent repairman.

Sears

**owner's
manual**

**MODEL NO.
536.918300**

**SEARS
SERVICE
is at
YOUR
SERVICE**

HOW TO ORDER REPAIR PARTS

The Model Number will be found on a plate attached to the main frame. Always mention the Model Number when requesting service or repair parts for your CRAFTSMAN SNOW THROWER.

All parts listed herein may be ordered through SEARS, ROEBUCK AND CO. or SIMPSON-SEARS LIMITED Retail or Catalog Stores. If the parts you need are not stocked locally, your order will be electronically transmitted to a SEARS Repair Parts Distribution Center for expedited handling.

WHEN ORDERING REPAIR PARTS, ALWAYS GIVE THE FOLLOWING INFORMATION AS SHOWN IN THIS LIST:

1. The PART NUMBER
2. The PART DESCRIPTION
3. The MODEL NUMBER - 536.918300
4. The NAME OF ITEM - Snow Thrower
5. The ENGINE MODEL NUMBER - 143.696102

"Your Sears merchandise has added value when you consider that Sears has service units nationwide staffed with Sears trained technicians . . . professional technicians specifically trained on Sears products, having the parts, tools and equipment to insure that we meet our pledge to you . . . we service what we sell."

SEARS, ROEBUCK AND CO., Chicago, Illinois 60684 U.S.A.